

STATE OF WISCONSIN
 WISCONSIN DEPARTMENT OF TRANSPORTATION
 TOWN PLAT RECORD

35-004

DATE	MILEAGE FOR LOCAL ROADS/STREETS	LOCAL ROADS/STREETS Certified in accordance with sec. 86.30 Wis. stat.	
(1) 4-1-19	78.66	Name:	Title:
(2) 1-1-20		Signature:	Date:
(3) 4-1-20			

MILEAGE FOR COUNTY TRUNKS	MILEAGE FOR COUNTY OTHER ROADS
26.60	00.00

TOWN OF
BRADLEY
 COUNTY: LINCOLN

- (1) THIS DATA REPRESENTS THE LAST CERTIFIED MILEAGE AS CORRECTED BY WISDOT WHICH MAY HAVE BEEN USED FOR PAST TRANSPORTATION AIDS.
- (2) THE TOWN CHAIRMAN OR CITY/VILLAGE CLERK IS TO FILL IN THE MILEAGE TO BE CERTIFIED AS OPEN TO THE PUBLIC AS OF THE FOLLOWING JANUARY, INCLUDING THE NEW CHANGES THAT ARE MADE ON THE PLAT.
- (3) THIS DATA REPRESENTS MILEAGE ADJUSTMENTS MADE BY WISDOT DUE TO FIELD VERIFICATION, INVENTORY, ANNEXATION, ETC. TRANSPORTATION AID PAYMENTS MAY BE MADE BASED ON THIS FIGURE.

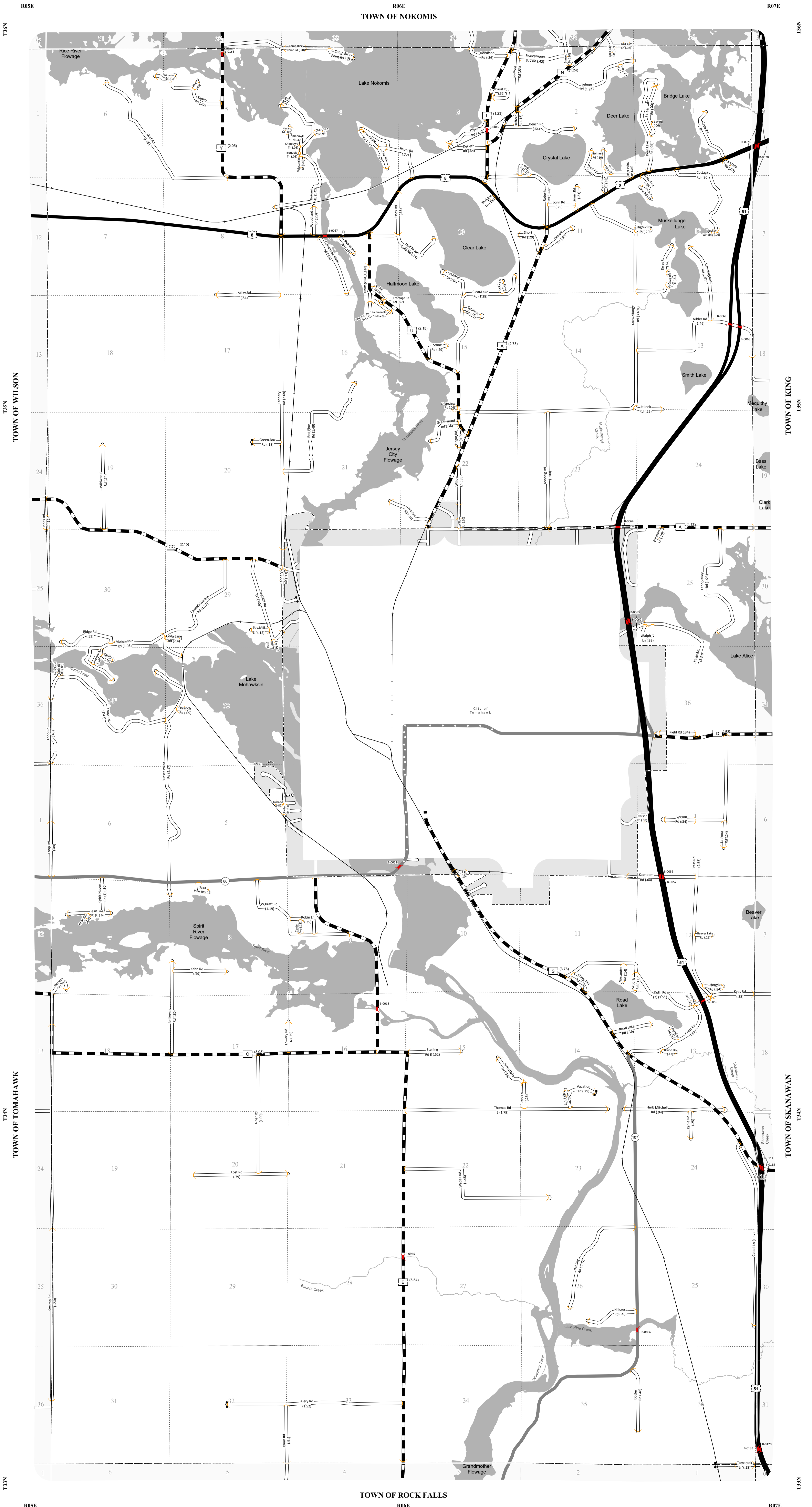

LEGEND:

- County Trunk Highway
- Local Road
- Park Road-Local
- US Highway
- State Trunk
- State On/Off Ramp
- State Connector
- State Connecting Highway
- Railroad
- CVT Border
- PLSS Border
- Bridge
- Gate
- Route Identifier

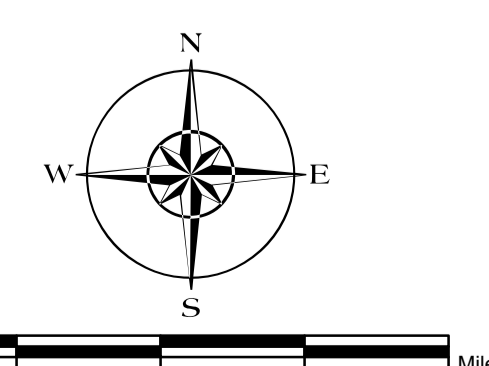

The information contained on this map was created for the official use of the Wisconsin Department of Transportation (WisDOT). Any other use while not prohibited, is the sole responsibility of the user. WisDOT expressly disclaims all liability regarding fitness of use of the information for other than official WisDOT business.