

This document contains confidential or proprietary information of URBAN CONSTRUCTION COMPANY. Neither this document nor the information herein is to be reproduced, distributed, used or in part except as specifically authorized by URBAN CONSTRUCTION COMPANY.

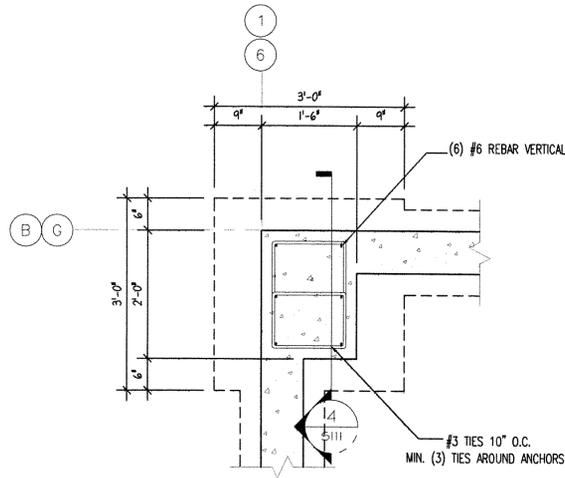

1 PIER PLAN VIEW
SIII 3/4" = 1'-0"

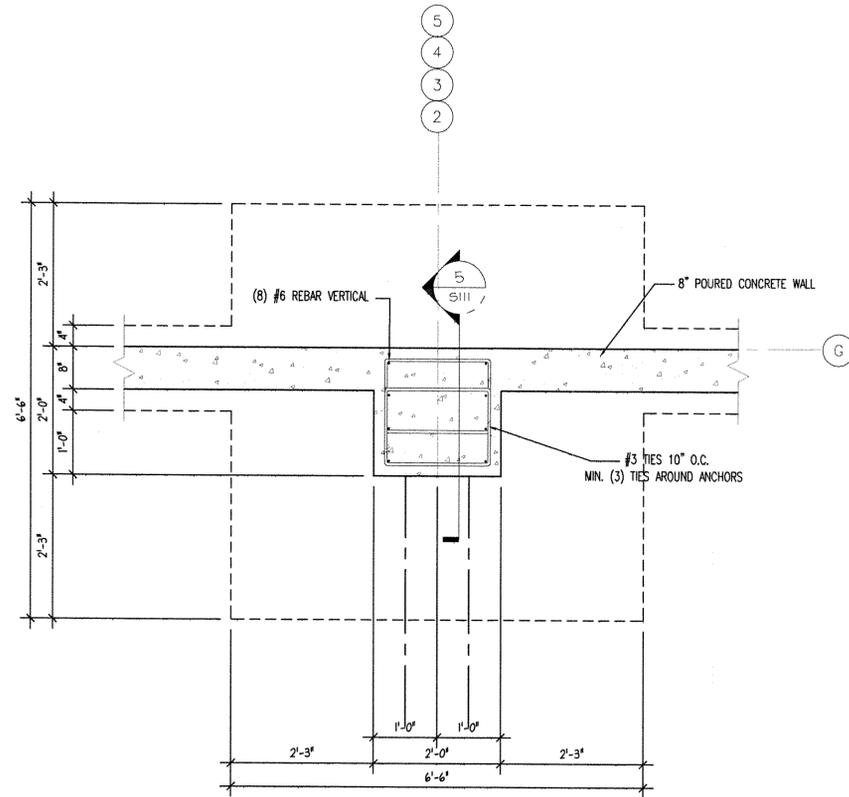

2 PIER PLAN VIEW
SIII 3/4" = 1'-0"

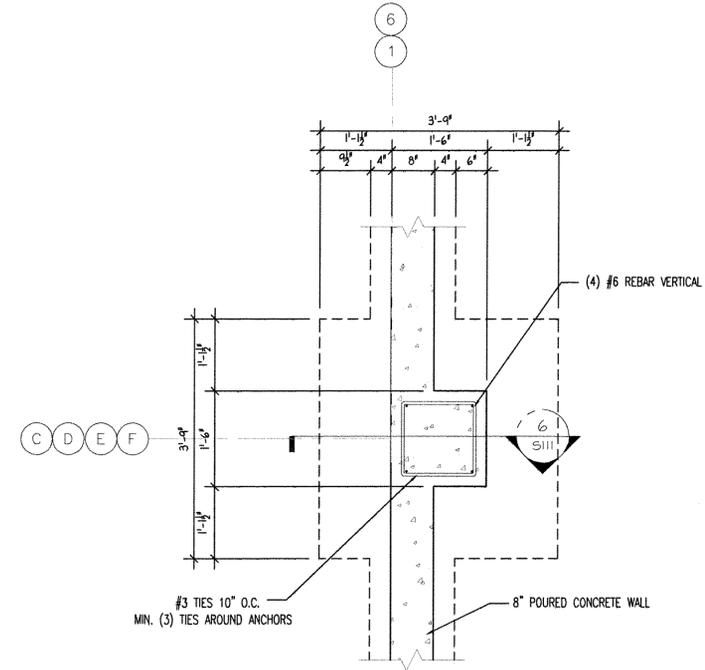

3 PIER PLAN VIEW
SIII 3/4" = 1'-0"

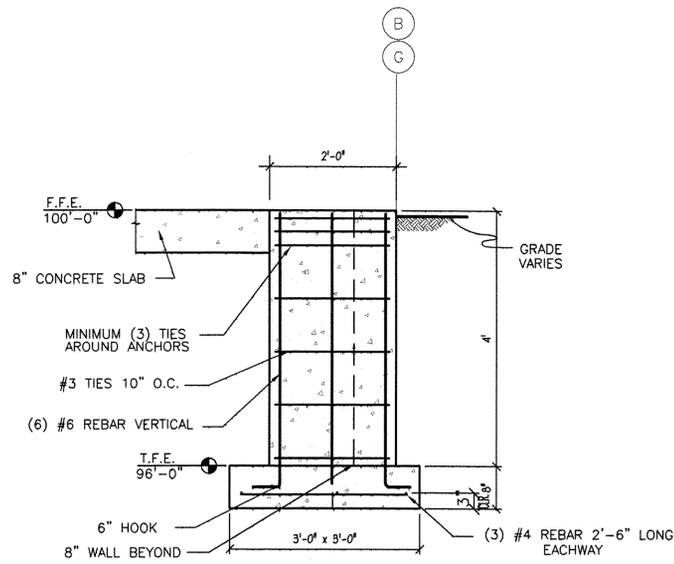

4 PIER SECTION VIEW
SIII 3/4" = 1'-0"

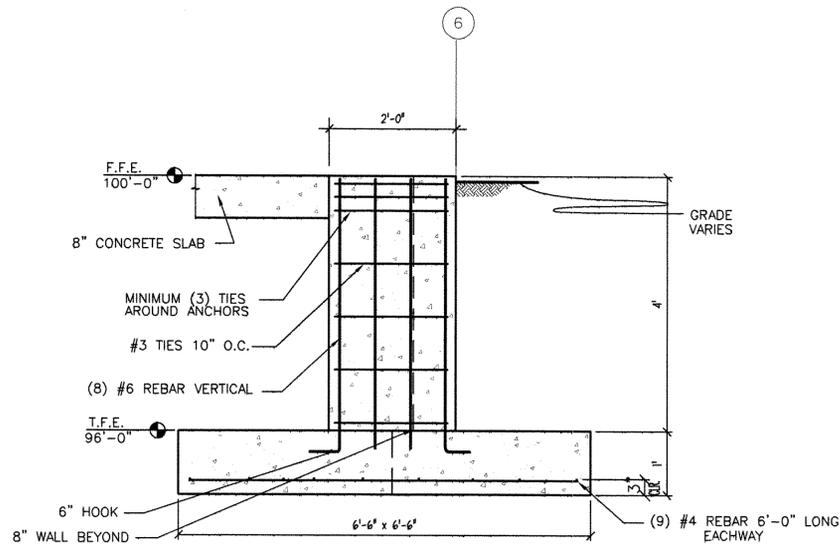

5 PIER SECTION VIEW
SIII 3/4" = 1'-0"

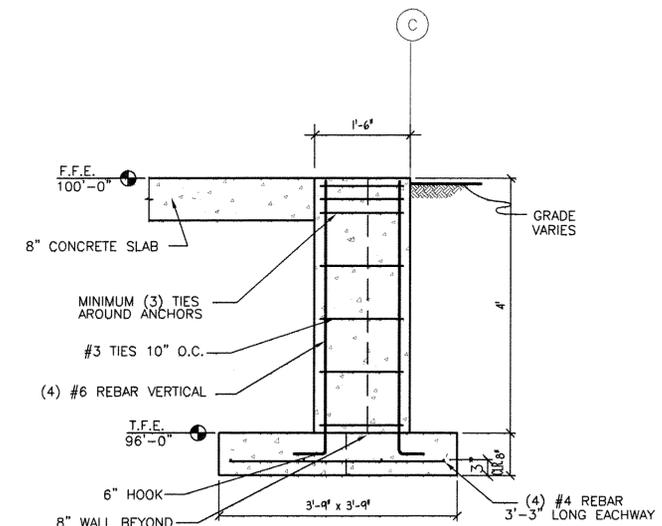

6 PIER SECTION VIEW
SIII 3/4" = 1'-0"

URBAN CONSTRUCTION COMPANY
 2005 Cassidy Drive - Wausau, WI 54401
 Tel: (715) 675-9425 - FAX: (715) 675-9781
 email: urban@dwave.net

REVISIONS	
NUMBER	DESCRIPTION

LINCOLN COUNTY HIGHWAY DEPARTMENT
 MERRILL, WI

KEY

CONSULTANT

DRAWN BY Ellen Kaldinski	DATE 5/16/01
CHECKED BY	DATE
SCALE 3/4" = 1'-0"	FILE NAME 01516S111
CONTRACT NUMBER	00-166
DRAWING NUMBER	01516
DESCRIPTION FOUNDATION DETAILS	
SHEET NUMBER S111	
BINDING ORDER	SHEET OF