

REVISION DATE 9/11/90	ROUTE	COUNTY	DATE	R/W PROJECT NUMBER	SHEET NUMBER
	C.T.H. CC	LINCOLN		9408-02-00	
	SCALE, FT.	GRID FACTOR		FEDERAL PROJECT NUMBER	4.4
	0 100 200				

**BEGIN RELOCATION ORDER  
PROJECT 9408-02-00**  
 STA. 1099+00  
 Y = 128,400.00 (±200')  
 X = 2,036,600.00 (±200')  
 99.98' NORTH AND 1.80' WEST OF THE  
 WEST QUARTER CORNER OF SECTION 15,  
 T34N, R5E.

MARY RICHTER &  
SUSAN JEAN RICHTER

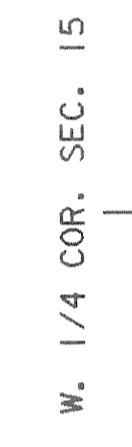

BERNTSFN MONUMENT  
STA. 1100+00, 0.00 LT.

THEODORE PIERCE, JR. &  
JOYCE C. PIERCE

WISCONSIN PUBLIC SERVICE

DONALD J. KLEICH & ADELE A. KLEICH  
L.C. GEORGE E. LOESCH

PATRICK D. MORRIS &  
LORETTA D. MORRIS

DONALD F. RENN &  
KIM M. FINDLER

GENERAL TELEPHONE COMPANY  
OF WISCONSIN

JACK SICKLER, ATHELEHE SICKLER  
RICK R. SICKLER, LOIS M. SICKLER  
RUSSEL HARSCH, PEGGY HARSCH  
GERALD WOYCIK, BECKY WOYCIK

OLAF HAUGEN JR., DOROTHY G. HAUGEN,  
PERCY O. GYLAND, ARDIS H. GYLAND,  
BELLE KALLAND, WILLIAM H. BROWN JR.,  
THERESSA G. BROWN, HOWARD R. GYLAND,  
MARIE SCHULTZ, JERRY SCHULTZ, EVELYN  
HUBRED, MELVIN K. HUBRED, FRANCES HUBRED

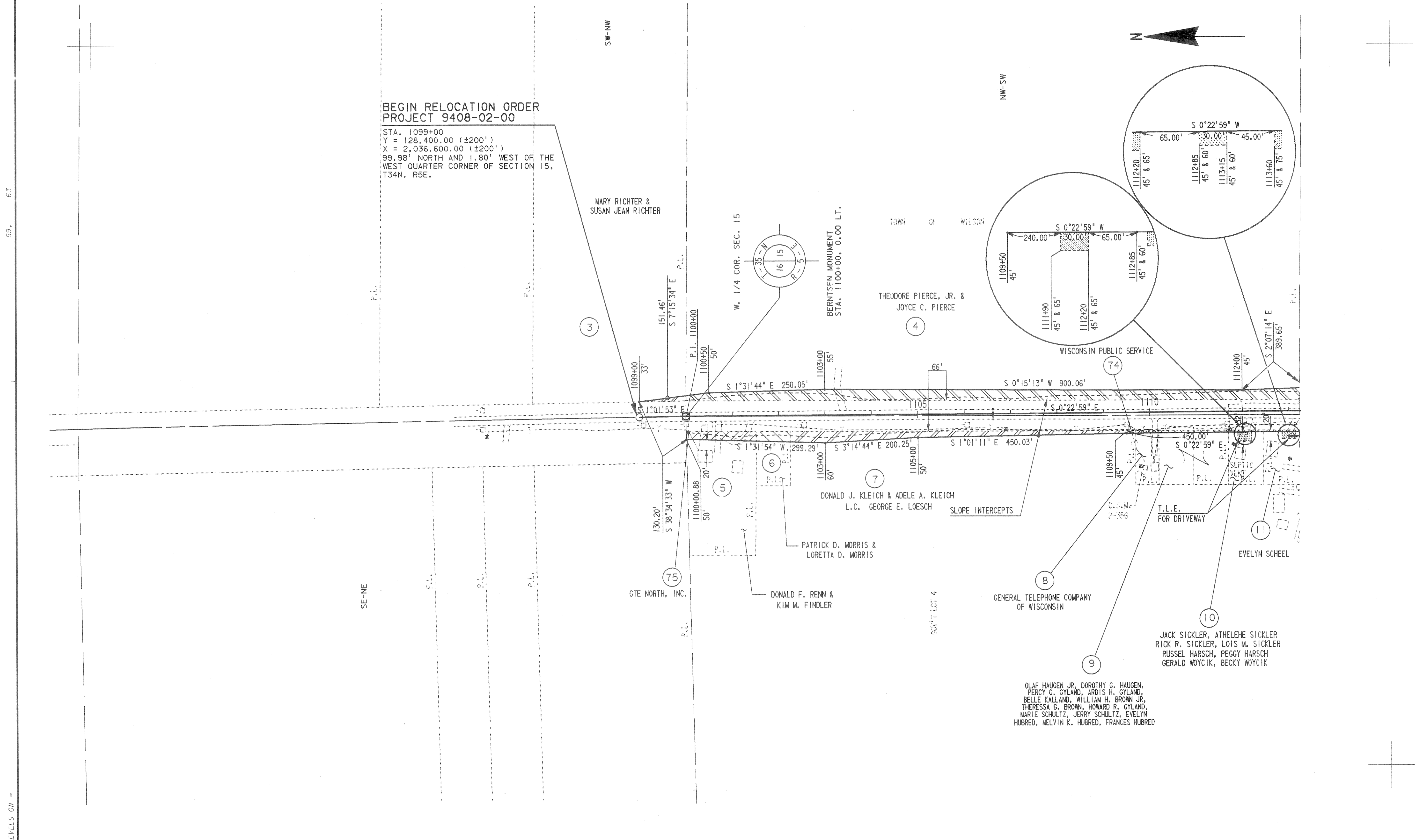

PLUT SCALE

PLUT NAME

REV. DATE

ORDINATOR

59, 63

LEVELS ON =

FILE NAME

REVISION DATE 9/11/90	ROUTE C.T.H. CC	COUNTY LINCOLN	DATE	R/W PROJECT NUMBER 9408-02-00	SHEET NUMBER 4.5
SCALE, FT. 0 100 200			GRID FACTOR	FEDERAL PROJECT NUMBER	

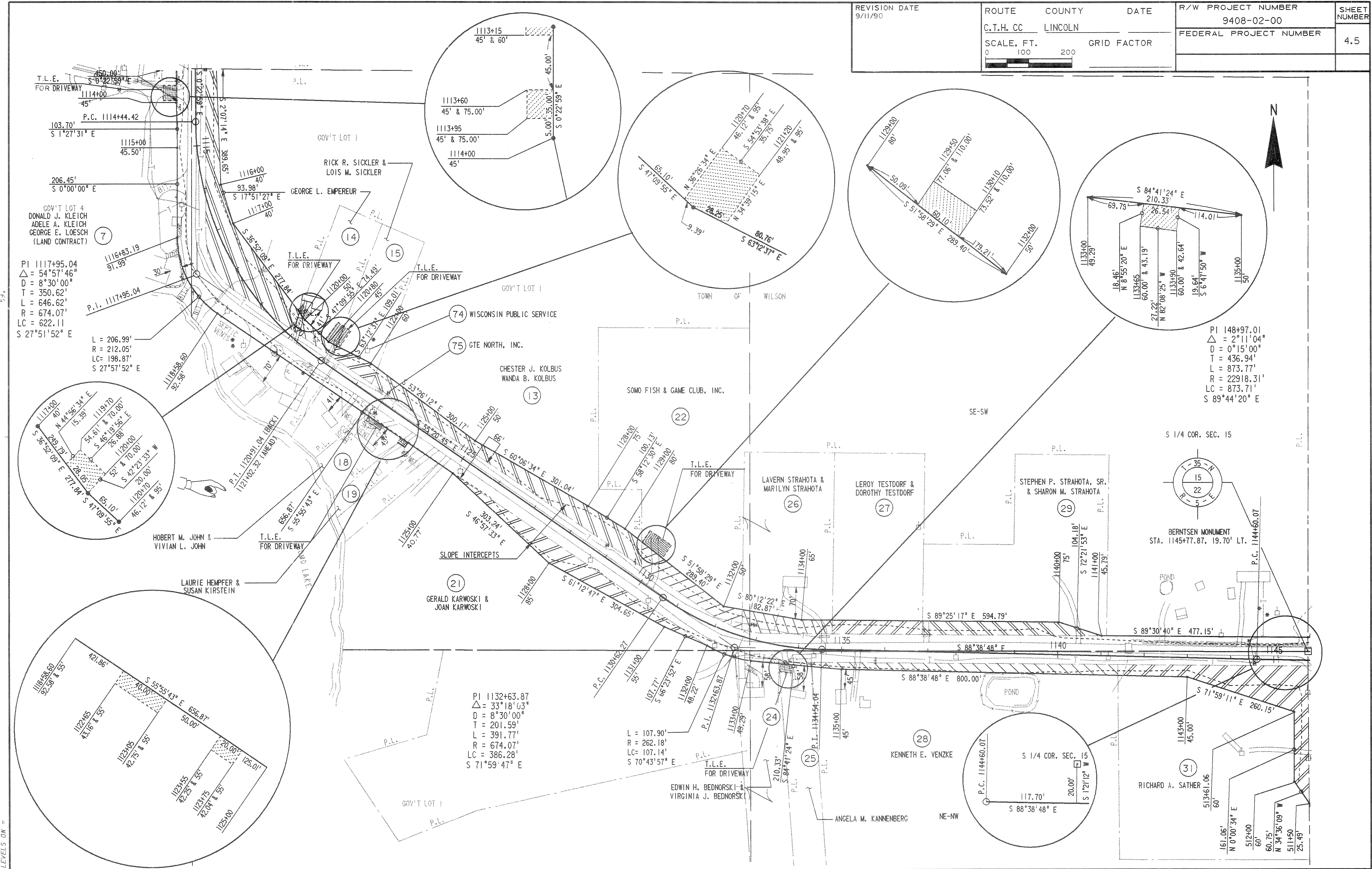

PLOT SCALE:

PLOT NAME:

REV. DATE:

ORIGINATOR:

LEVELS ON =

REVISION DATE 9/11/90	ROUTE C.T.H. CC	COUNTY LINCOLN	DATE	R/W PROJECT NUMBER 9408-02-00	SHEET NUMBER 4.6
	SCALE, FT. 0 100 200	GRID FACTOR		FEDERAL PROJECT NUMBER	

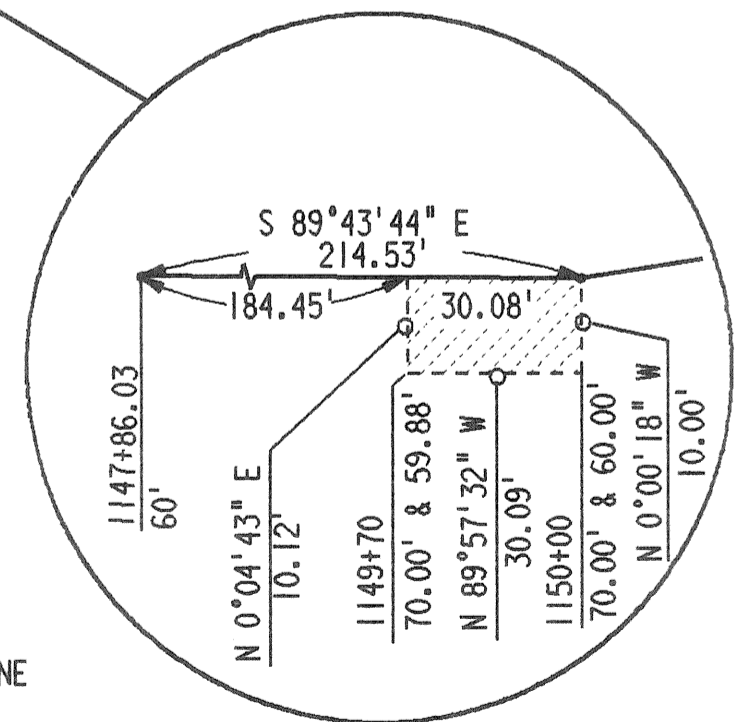
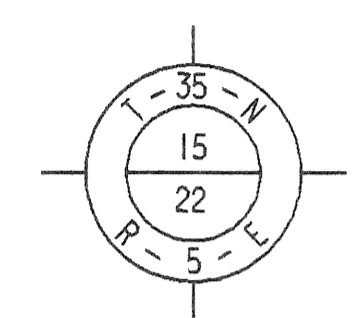
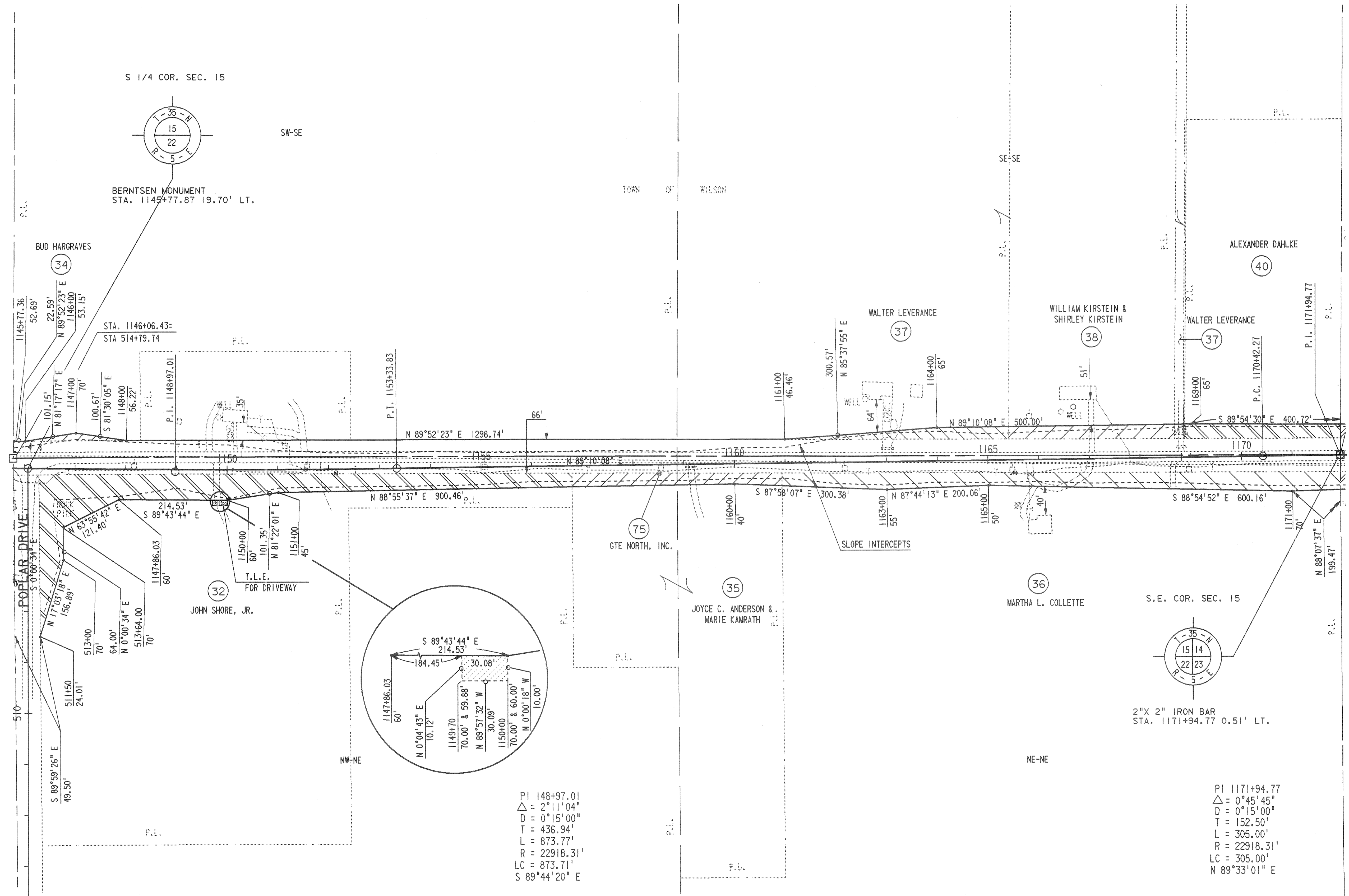

PI 148+97.01  
 $\Delta = 2^{\circ}11'04''$   
 $D = 0^{\circ}15'00''$   
 $T = 436.94'$   
 $L = 873.77'$   
 $R = 22918.31'$   
 $LC = 873.71'$   
 $S 89^{\circ}44'20'' E$

PI 1171+94.77  
 $\Delta = 0^{\circ}45'45''$   
 $D = 0^{\circ}15'00''$   
 $T = 152.50'$   
 $L = 305.00'$   
 $R = 22918.31'$   
 $LC = 305.00'$   
 $S 89^{\circ}33'01'' E$

LEVELS ON #2,3,4,5,6,7,8,9,10,11,12,13,14,15,16,17,18,19,20,21,22,23,24,25,26,27,28,29,30,31,32,33,34,35,36,37,38,39,40,41,42,43,44,45,46,47,48,49,50,51,52,53,54,55,56,57,58,59,60,61,62.

ORIGINATOR: REV. DATE: PLOT NAME: PLOT SCALE:

REVISION DATE  
9/11/90

ROUTE COUNTY DATE  
C.T.H. CC LINCOLN

R/W PROJECT NUMBER  
9408-02-00

SHEET  
NUMBER

SCALE, FT. GRID FACTOR  
0 100 200

FEDERAL PROJECT NUMBER

4.7

LEVELS ON #8.3, 4.5, 6.7, 8.9, 10.1, 11.2, 13.1, 14.1, 15.1, 16.1, 17.1, 18.1, 19.0, 2.1, 2.2, 2.3, 2.4, 2.5, 2.6, 2.7, 2.8, 2.9, 3.0, 3.1, 3.2, 3.3, 3.4, 3.5, 3.6, 3.7, 3.8, 3.9, 4.0, 4.1, 4.2, 4.3, 4.4, 4.5, 4.6, 4.7, 4.8, 4.9, 5.0, 5.1, 5.2, 5.3, 5.4, 5.5, 5.6, 5.7, 5.8, 5.9, 6.0, 6.1, 6.2.

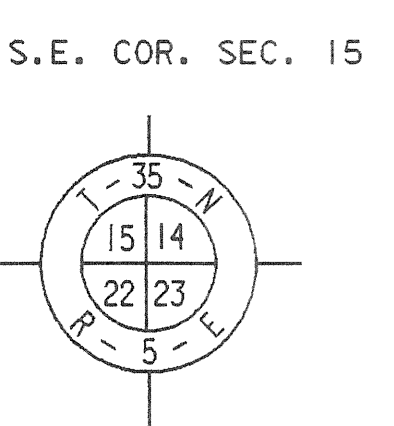
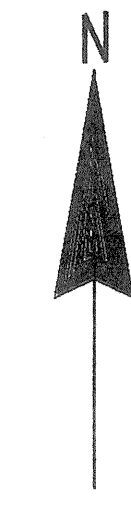
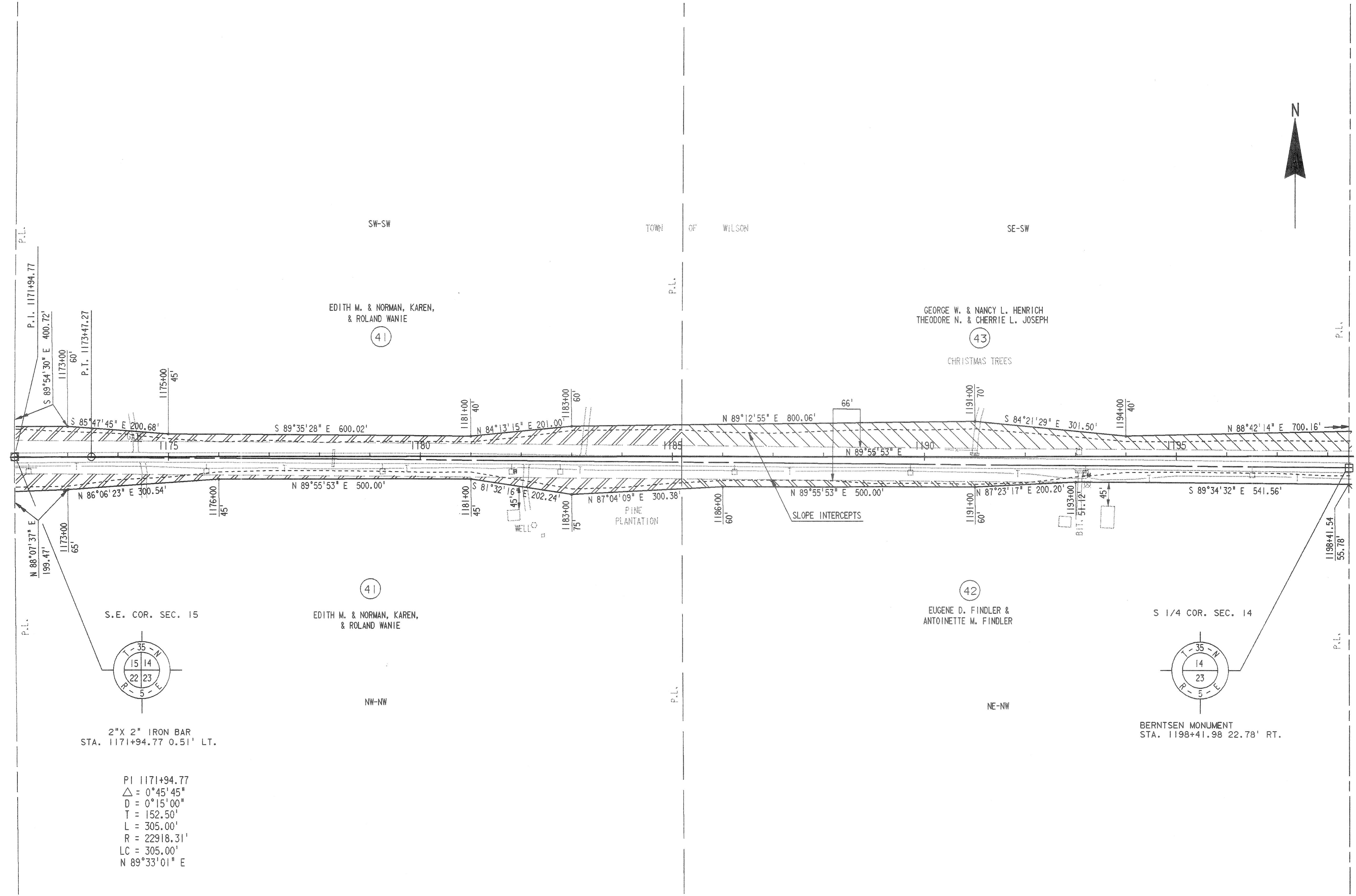

2" X 2" IRON BAR  
STA. 1171+94.77 0.51' LT.

PI 1171+94.77  
 $\Delta = 0^{\circ}45'45''$   
 $D = 0^{\circ}15'00''$   
 $T = 152.50'$   
 $L = 305.00'$   
 $R = 22918.31'$   
 $LC = 305.00'$   
 $N 89^{\circ}33'01'' E$

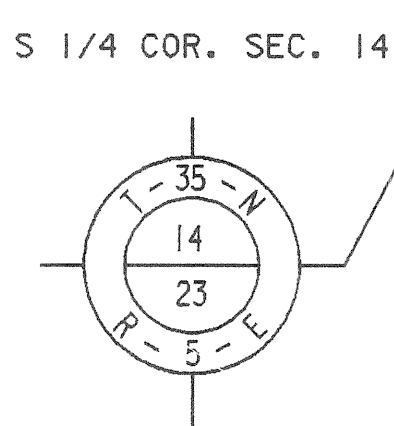

BERNTSEN MONUMENT  
STA. 1198+41.98 22.78' RT.

PLUT SCALE

PLUT NAME

REV. DATE

ORIGINATOR

REVISION DATE 9/11/90	ROUTE C.T.H. CC	COUNTY LINCOLN	DATE	R/W PROJECT NUMBER 9408-02-00	SHEET NUMBER 4.8
	SCALE, FT. 0 100 200	GRID FACTOR		FEDERAL PROJECT NUMBER	

PI 601+20.96  
 $\Delta = 14^{\circ}47'05''$   
 $D = 12^{\circ}30'00''$   
 $T = 59.47'$   
 $L = 118.28'$   
 $R = 458.37'$   
 $LC = 117.95'$   
 $N 11^{\circ}27'07'' W$

TIM MICHAEL & CYNTHIA M. FITZGERALD

WISCONSIN PUBLIC SERVICE

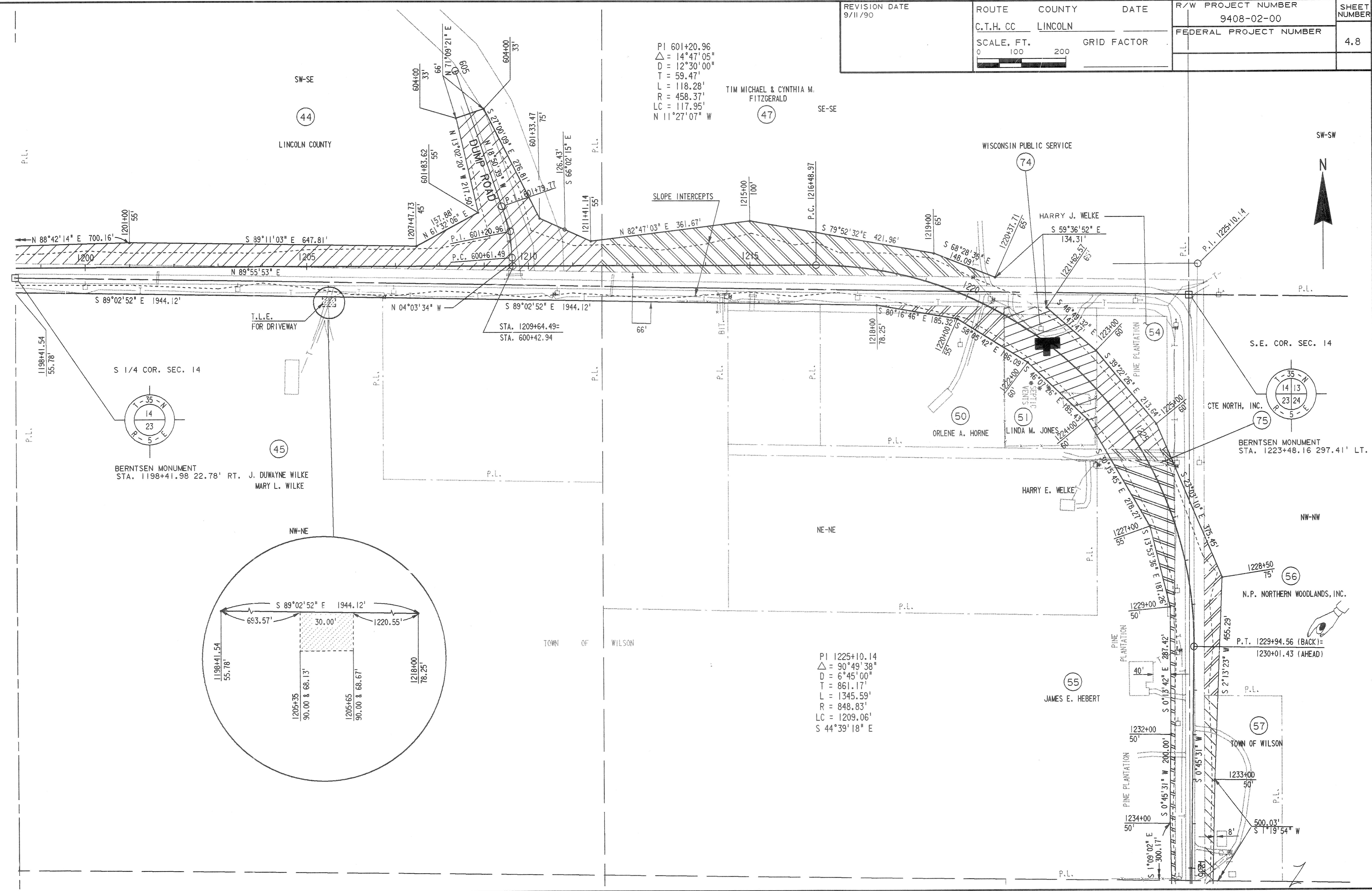
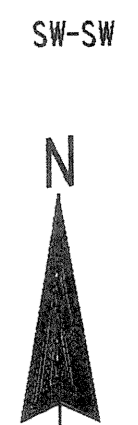

BERNTSEN MONUMENT  
 STA. 1198+41.98 22.78' RT. J. DUWAYNE WILKE  
 MARY L. WILKE

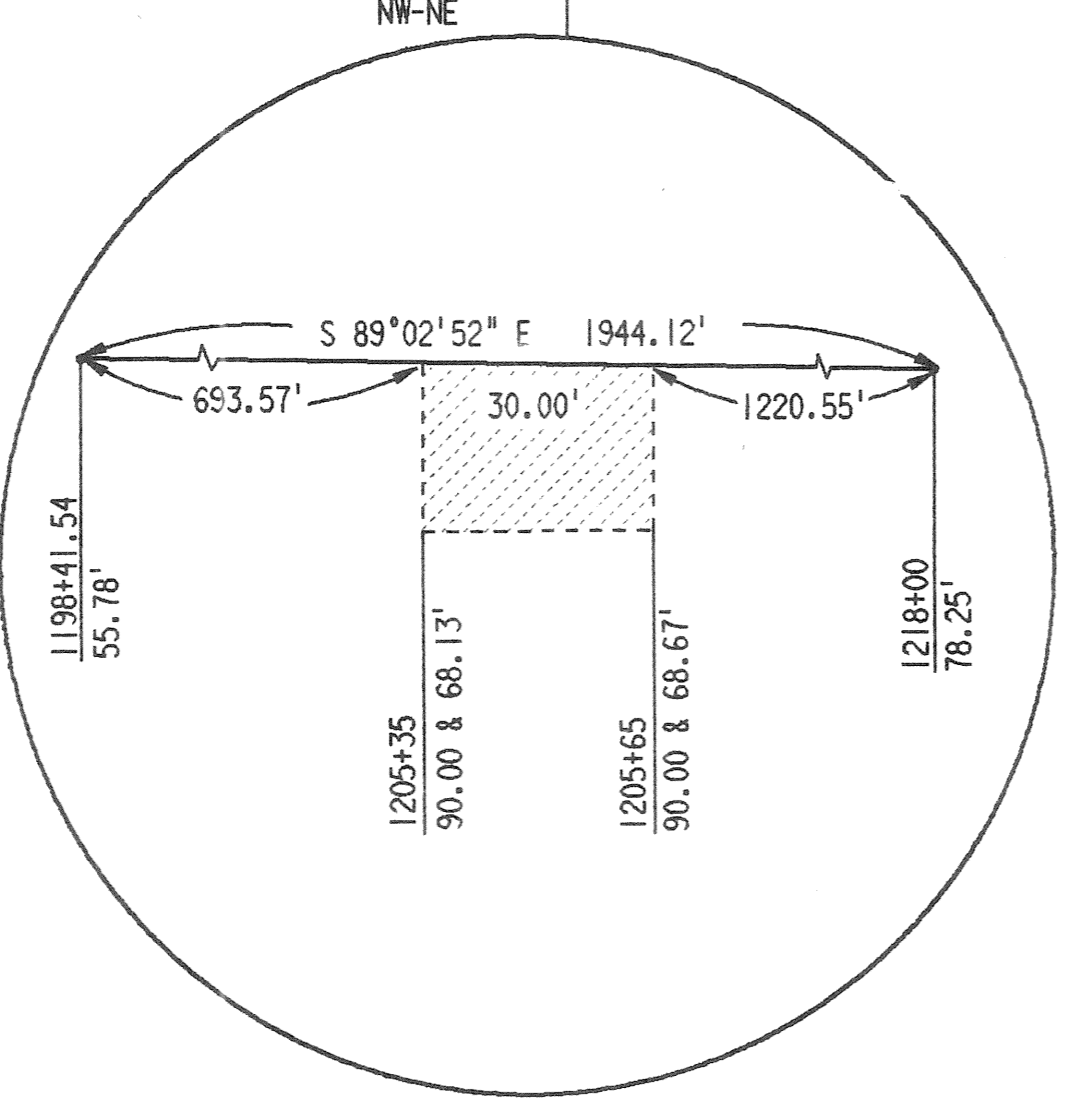

PI 1225+10.14  
 $\Delta = 90^{\circ}49'38''$   
 $D = 6^{\circ}45'00''$   
 $T = 861.17'$   
 $L = 1345.59'$   
 $R = 848.83'$   
 $LC = 1209.06'$   
 $S 44^{\circ}39'18'' E$

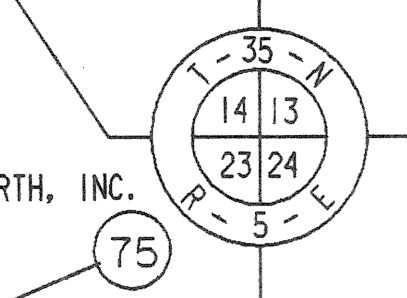

BERNTSEN MONUMENT  
 STA. 1223+48.16 297.41' LT.

N.P. NORTHERN WOODLANDS, INC.

TOWN OF WILSON

59'

LEVELS ON =

REVISION DATE 9/11/90	ROUTE C.T.H. CC	COUNTY LINCOLN	DATE	R/W PROJECT NUMBER 9408-02-00	SHEET NUMBER 4.9
	SCALE, FT. 0 100 200	GRID FACTOR		FEDERAL PROJECT NUMBER	

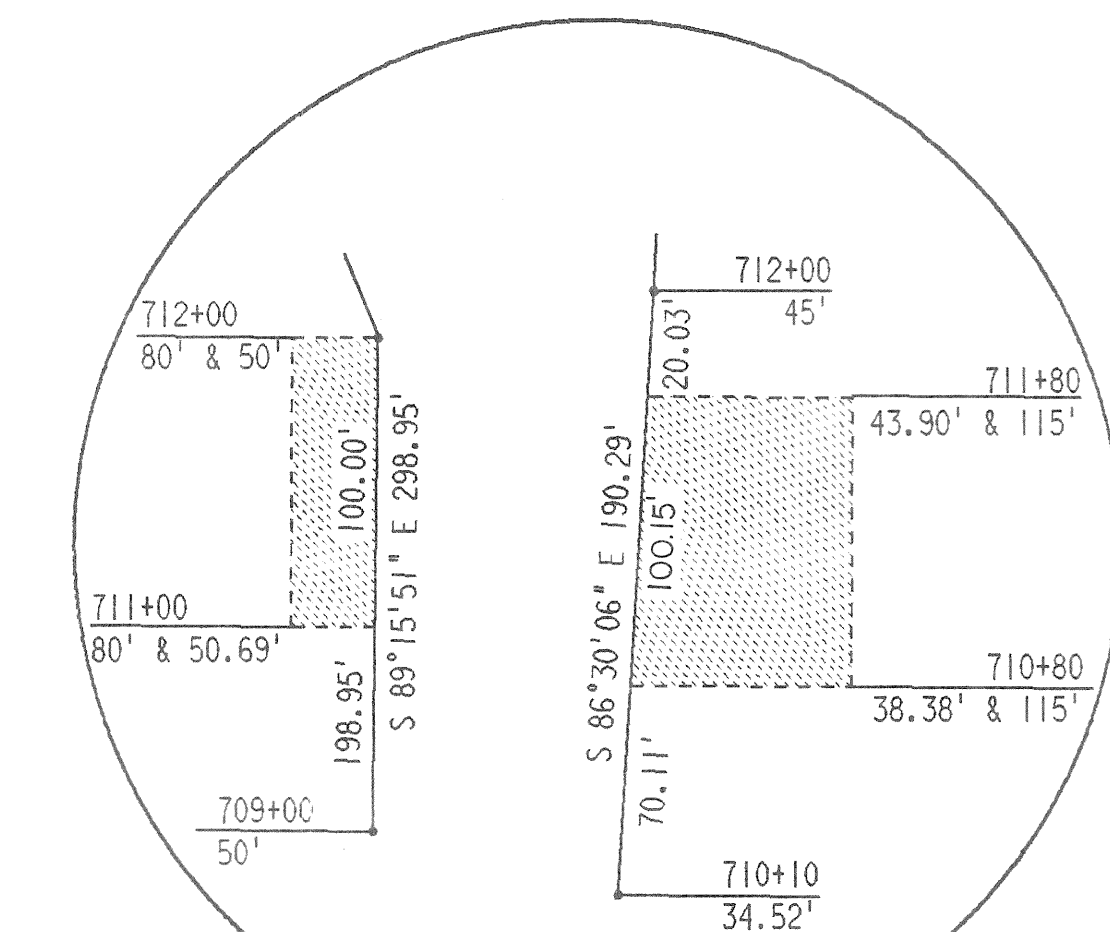
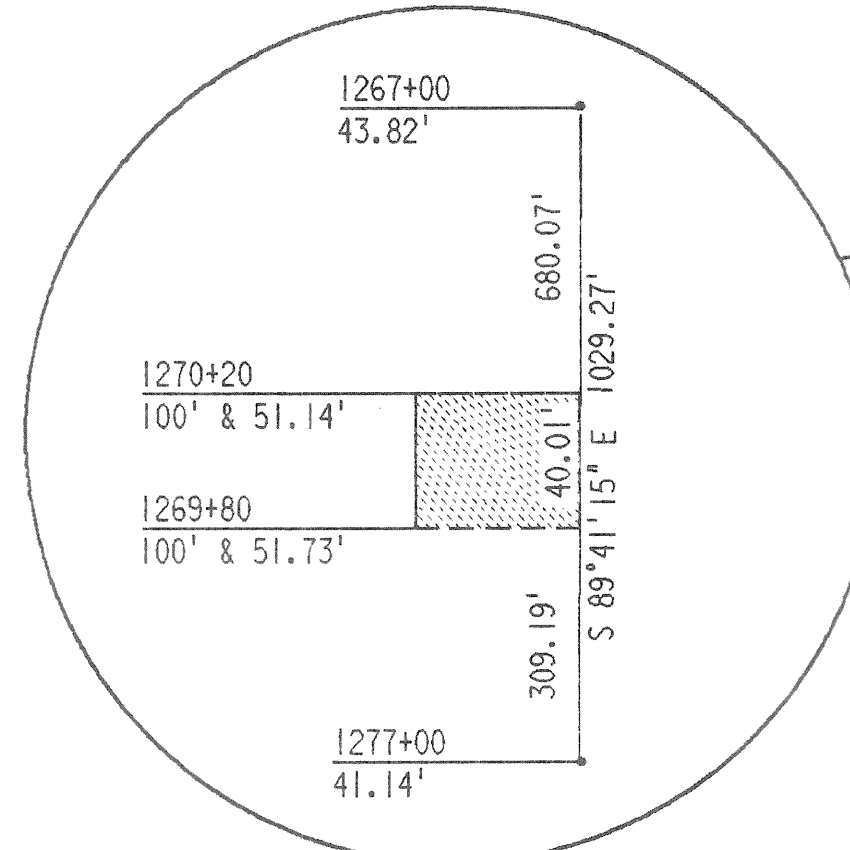
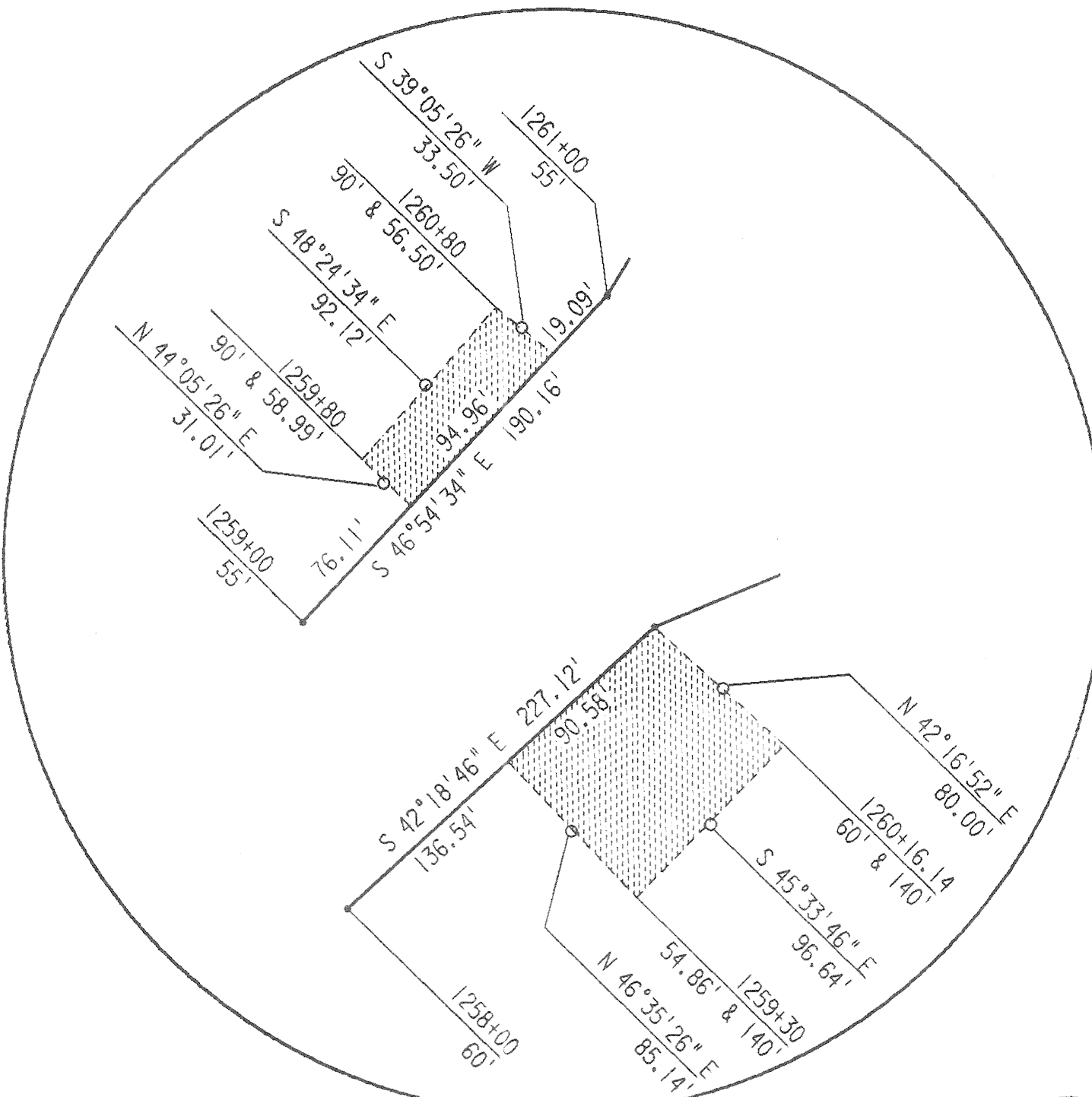
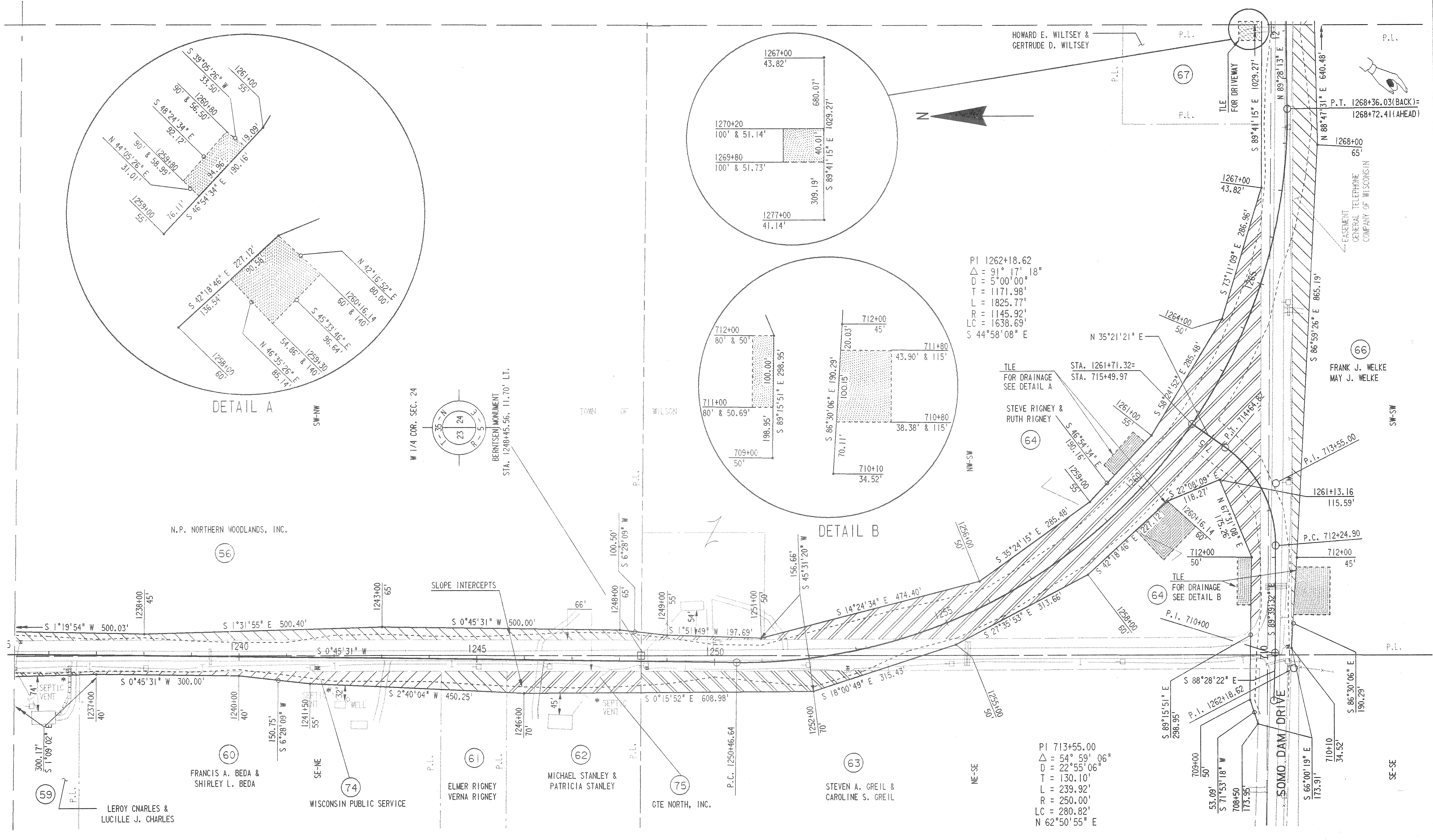

PI 1262+18.62  
 $\Delta = 91^\circ 17' 18''$   
 $D = 5'00'00''$   
 $T = 1171.98'$   
 $L = 1825.77'$   
 $R = 1145.92'$   
 $LC = 1638.69'$   
 $S 44^\circ 58' 08'' E$

PI 713+55.00  
 $\Delta = 54^\circ 59' 06''$   
 $D = 22'55'06''$   
 $T = 130.10'$   
 $L = 239.92'$   
 $R = 250.00'$   
 $LC = 280.82'$   
 $N 62^\circ 50' 55'' E$

LEVELS ON 2.3.4.5.6.7.8.9.10.11.12.13.14.15.16.17.18.19.20.21.22.23.24.25.26.27.28.29.30.31.32.33.34.35.36.37.38.39.40.41.42.43.44.45.46.47.48.49.50.51.52.53.54.55.56.57.58.59.60.61.62.

ORIGINATOR: REV. DATE: PLOT NAME: PLOT SCALE:

REVISION DATE 9/11/90	ROUTE C.T.H. CC	COUNTY LINCOLN	DATE	R/W PROJECT NUMBER 9408-02-00	SHEET NUMBER 4.10
	SCALE, FT. 0 100 200	GRID FACTOR		FEDERAL PROJECT NUMBER	

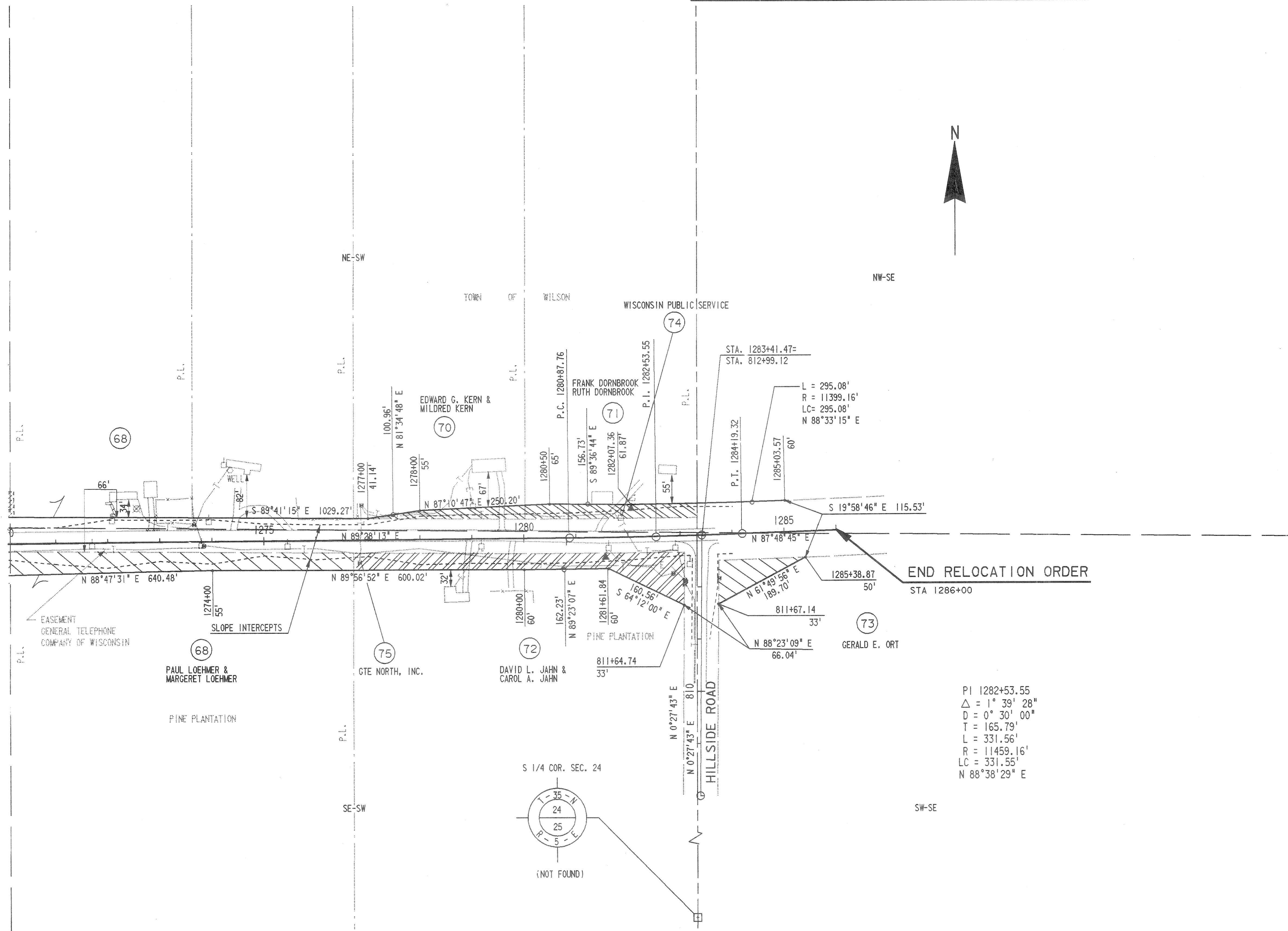
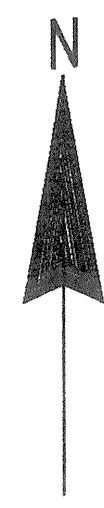

PI 1282+53.55  
 $\Delta = 1^\circ 39' 28''$   
 $D = 0^\circ 30' 00''$   
 $T = 165.79'$   
 $L = 331.56'$   
 $R = 11459.16'$   
 $LC = 331.55'$   
 $N 88^\circ 38' 29'' E$

END RELOCATION ORDER  
 STA 1286+00

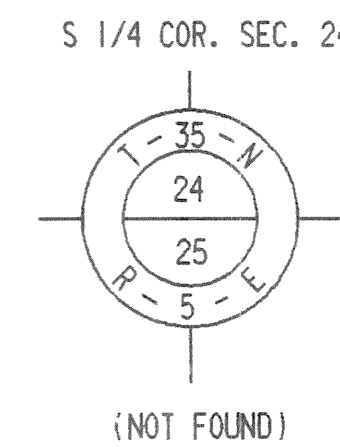

59.

LEVELS ON =