

915 mm GIRDER - SIDE VIEW

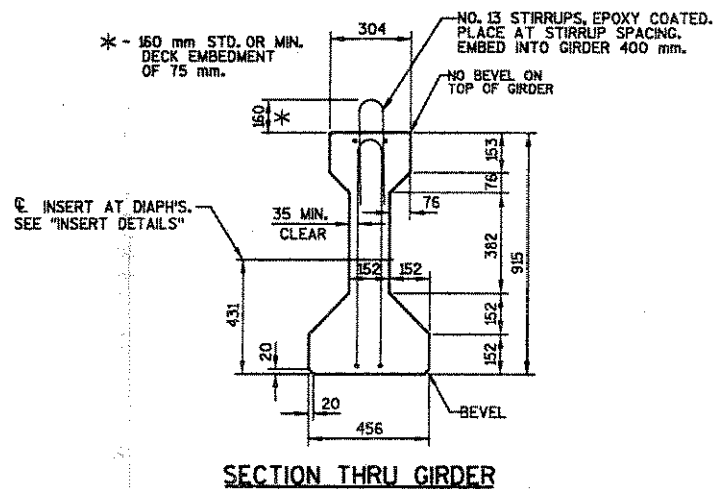

SECTION THRU GIRDER

NOTES

- ALL GIRDERS SHALL BE CAST FULL LENGTH AS SHOWN.
- PRESTRESSING STRANDS SHALL BE 13 mm # - 7 WIRE STRANDS WITH AN ULTIMATE STRENGTH OF 1860 MPa AND SHALL BE FLUSH WITH THE ENDS OF THE GIRDER.
- THE GIRDERS SHALL BE PROVIDED WITH A SUITABLE LIFTING DEVICE FOR HANDLING AND ERECTING THE GIRDERS.
- TOP OF GIRDERS TO BE ROUGH FLOATED AND BROOMED TRANSVERSELY FOR BONDING TO THE SLAB, EXCEPT THE OUTSIDE 50 mm OF GIRDER WHICH SHALL BE TROWEL FINISHED.
- #16 BARS MAY BE SPLICED AT THE 1/2 POINT OF GIRDER. LAP LENGTH 950 mm FOR NO. 16 BARS. BEND DOWN 256 mm AT ENDS.
- SPACING SHOWN FOR #13 STIRRUPS IS FOR GRADE 420 REINFORCEMENT. IF THE FABRICATOR WANTS TO BUILD A BAR STEEL CAGE BY WELDING LONGITUDINAL REINFORCEMENT TO THE #13 STIRRUPS, 2 OPTIONS ARE AVAILABLE:
 - USE ASTM A706M, GRADE 420 REINFORCEMENT AND THE STIRRUP SPACING AS SHOWN ON THE PLANS.
 - USE ASTM A615M, GRADE 300 REINFORCEMENT AND A MODIFIED STIRRUP SPACING SUBMITTED TO AND APPROVED BY THE STRUCTURES DEVELOPMENT SECTION.
- AN ALTERNATE EQUIVALENT OF WELDED WIRE FABRIC (WWF) MAY BE SUBSTITUTED FOR THE STIRRUP REINFORCEMENT SHOWN, UPON APPROVAL OF THE STRUCTURES DEVELOPMENT SECTION.
- WELDED WIRE FABRIC SHALL CONFORM TO THE REQUIREMENTS OF ASTM A497.

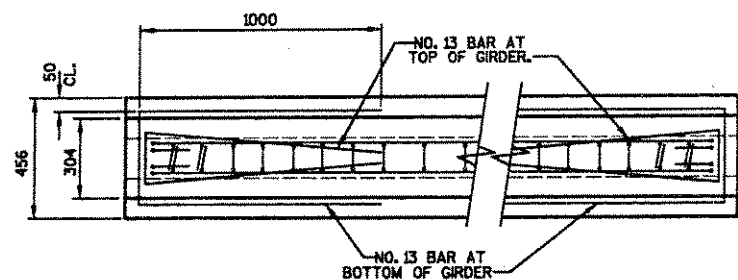

TOP VIEW OF GIRDER

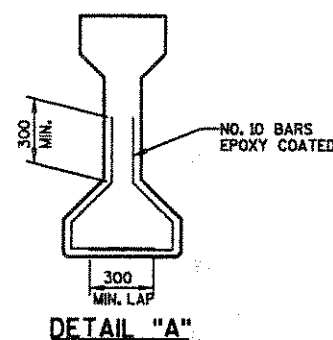

DETAIL "A"

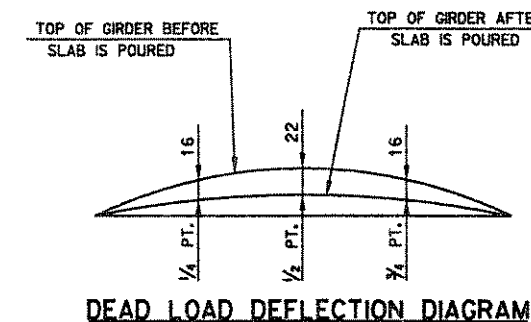

DEAD LOAD DEFLECTION DIAGRAM

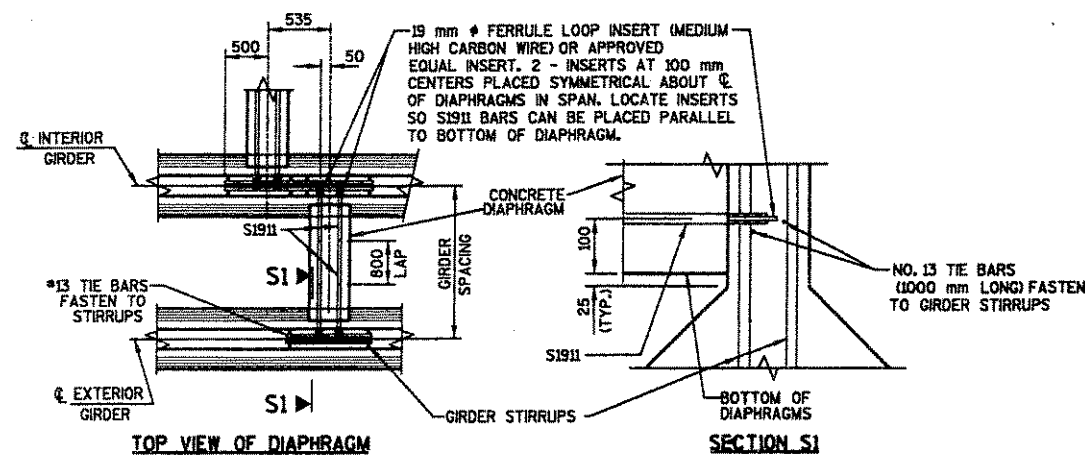

TOP VIEW OF DIAPHRAGM

SECTION S1

INSERT DETAILS AT DIAPHRAGMS
(FOR DIAPHRAGM LOCATION SEE SUPERSTRUCTURE PLAN - SHEET 7)

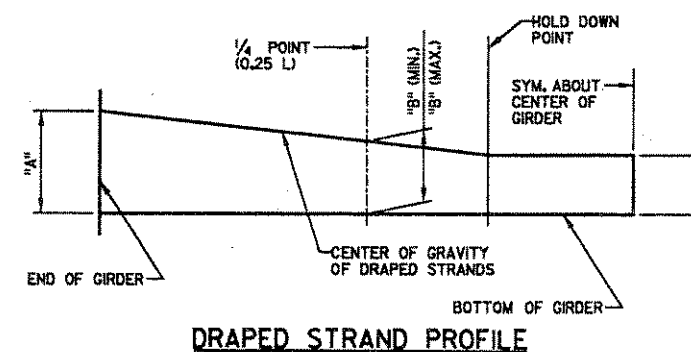

DRAPED STRAND PROFILE

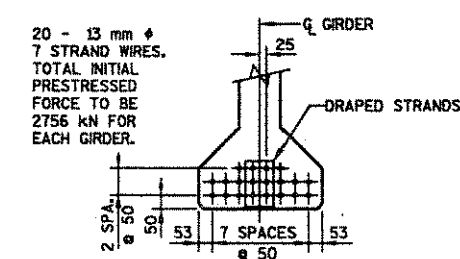

SECTION THRU GIRDER AT C SPAN

GIRDER DATA		LOW RELAXATION
GIRDER LENGTH "L" REQUIRED		19 300
F _{ci} (MPa) *	DRAPED PATTERN	34.9
	SPREAD PATTERN	
DRAPED STRANDS	DIMENSION "A"	550
	DIMENSION "B" (MINIMUM)	212
	DIMENSION "B" (MAXIMUM)	287
	DIMENSION "C"	100

* MINIMUM CYLINDER STRENGTH OF CONCRETE AT TIME OF TRANSFER OF PRESTRESS FORCE.

No.	Date	Revision	By
STATE OF WISCONSIN DEPARTMENT OF TRANSPORTATION			
STRUCTURE B-35-136			
Const. Spec.	WI "96"	Drawn By RLR	Plans Checked JMB
915 mm PRESTRESSED GIRDER DETAILS			SHEET 6 OF 9

PLOT SCALE:

MSA #: 93966106

REV. DATE: 9-22-97

ORIGINATOR: RLR
LEVELS ON - 1, 2, 3, 4, 5, 6, 7, 8, 9, 10, 11, 12, 13, 14, 15, 16, 17, 18, 19, 20, 21, 22, 23, 24, 25, 26, 27, 28, 29, 30, 31, 32, 33, 34, 35, 36, 37, 38, 39, 40, 41, 42, 43, 44, 45, 46, 47, 48, 49, 50, 51, 52, 53, 54, 55, 56, 57, 58, 59, 60, 61, 62, 63