

SUBSET: TRBRIDGE
FILE NAME: 09231GP

LEVELS ON 4,2,3,4,5,6,7,8,9,10,11,12,13,14,15,16,17,18,19,20,21,22,23,24,25,26,27,28,29,30,31,32,33,34,35,36,37,38,39,40,41,42,43,44,45,46,47,48,49,50,51,52,53,54,55,56,57,58,59,60,61,62,63

TOTAL ESTIMATED QUANTITIES

BID ITEMS	UNIT	W. ABUT.	E. ABUT.	SUPER.	TOTAL
REMOVING OLD BRIDGE, STA. 10+00	L.S.	-----	-----	-----	1
EXCAVATION FOR STRUCTURES, BRIDGES B-35-110	L.S.	-----	-----	-----	1
CONCRETE MASONRY, BRIDGES	C.Y.	18.2	18.2	48.6	85
PROTECTIVE SURFACE TREATMENT	GAL.	-----	-----	7	7
PRESTRESSED GIRDER, I-TYPE, 36-INCH	L.F.	-----	-----	212	212
HIGH-STRENGTH BAR STEEL REINFORCEMENT, BRIDGES	LB.	1,580	1,580	5,220	8,380
COATED HIGH-STRENGTH BAR STEEL REINFORCEMENT, BRIDGES	LB.	-----	-----	4,550	4,550
NON-LAMINATED ELASTOMERIC BEARING PADS	EACH	4	4	-----	8
STEEL PILING, DELIVERED AND DRIVEN, HP 10-INCH 42 POUND	L.F.	180	140	-----	320
TUBULAR RAILING, TYPE F, STRUCTURE B-35-110	L.S.	-----	-----	-----	1
HEAVY RIPRAP	C.Y.	90	95	-----	185
GEOTEXTILE FABRIC, TYPE HR	S.Y.	150	155	-----	305
PILE POINTS	EACH	4	4	-----	8
NON-BID ITEMS					
FILLER	SIZE	-----	-----	-----	1/2 & 3/4
POLYVINYL CHLORIDE WATERSTOP	L.F.	34	34	-----	68

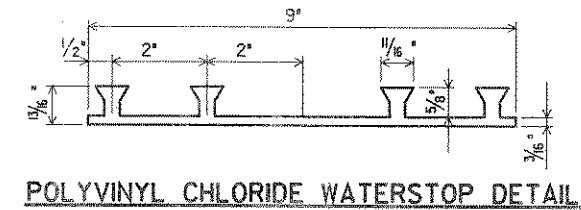

GENERAL NOTES

DRAWINGS SHALL NOT BE SCALED.
 BAR STEEL REINFORCEMENT SHALL BE EMBEDDED 2" CLEAR UNLESS SHOWN OR NOTED OTHERWISE.
 THE FIRST DIGIT OF A THREE DIGIT BAR NO. AND THE FIRST TWO DIGITS OF A FOUR DIGIT BAR NO. SIGNIFIES THE BAR SIZE.
 JOINT FILLER SHALL CONFORM TO THE REQUIREMENTS OF A.A.S.H.T.O. DESIGNATION M 153, TYPE I, II OR III OR A.A.S.H.T.O. DESIGNATION M 213.
 THE SLOPE OF THE FILL IN FRONT OF THE ABUTMENTS SHALL BE COVERED WITH HEAVY RIPRAP TO THE EXTENT SHOWN ON THE GENERAL PLAN SHEET AND IN THE ABUTMENT DETAILS.
 PROTECTIVE SURFACE TREATMENT IS TO BE APPLIED TO THE TOP OF DECK.
 ELASTOMERIC BEARING PADS NEED NOT BE INDIVIDUALLY MOLDED PROVIDED THE CUT EDGES ARE SMOOTH AND TRUE.
 THE EXISTING BRIDGE (P-35-87) IS A TWO SPAN STEEL DECK GIRDER BRIDGE WITH A WIDTH OF 25 FEET AND AN OVERALL LENGTH OF 34 FEET.

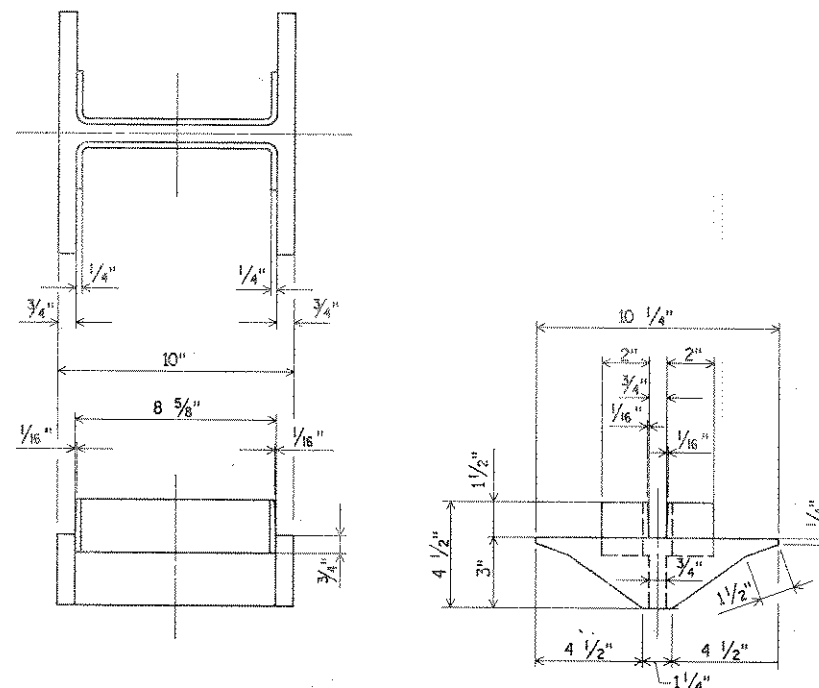
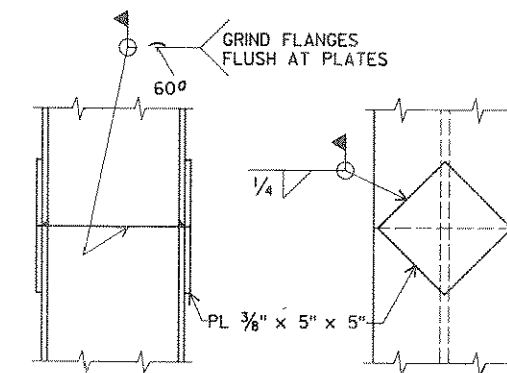

No.	Date	Revision	By
PLANS PREPARED BY			
AYRES ASSOCIATES Engineers/Architects Planners/Surveyors Owen Ayres & Associates Inc. Eau Claire, Wisconsin			
STATE OF WISCONSIN DEPARTMENT OF TRANSPORTATION			
STRUCTURE B-35-110			
Const. Spec.	1989	Drawn By G.L.D.	Plans Checked C.B.M.
QUANTITIES & NOTES			SHEET 2 OF 9 X 82833

BACK CHECKED BY: _____
CORRECTED BY: _____