

LEGEND

- ① W6x25 WITH 1 1/4" DIA. HOLES ON EACH SIDE OF POST FLANGE. FOR STUD NO. 6. CUT BOTTOM OF POST TO MATCH CROSS SLOPE OF ROADWAY. PLACE POST VERTICAL. PLACE POST NORMAL TO GRADE LINE.
- ② PLATE 1"x9 1/2"x0'-10". WITH 1 1/16"x1 1/2" SLOTTED HOLES FOR ANCHOR BARS NO.3. WELD TO NO. 1 AS SHOWN.
- ③ A449 OR MATERIAL OF EQUIVALENT YIELD STRENGTH AND ELONGATION ANCHOR BAR 7/8" DIA.x 1'-3" LONG AT END POSTS AND 10" LONG AT ALL OTHER POST LOCATIONS FOR CONCRETE SLAB STRUCTURES AND 8 1/2" LONG AT ALL OTHER POST LOCATIONS FOR PRESTRESSED GIRDER STRUCTURES. (MIN. YIELD OF 92 K.S.I. AND ELONGATION OF 14%) WITH A325 NUT AND WASHER. 4 REQ'D. PER POST. THREAD 3" AND PLACE NORMAL TO PLATE NO. 3. CHAMFER TOP OF BOLTS BEFORE THREADING.
- ④ BAR 3/4" SQ.x0'-8" LONG. WELD TO ANCHOR BAR NO. 3
- ⑤ TS 4x4x.25 STRUCTURAL TUBING, CONFORMING TO A.S.T.M. DESIGNATION A36. ATTACH TO WITH STUDS NO. 6.
- ⑥ 1 5/8" DIA.x 1 1/2" LONG SHOP WELDED STUDS, WITH HEX. NUT AND 2" WASHERS. 4 PER POSTS REQ'D. (2 REQ'D. AT EACH LOCATION.)
- ⑦ PLATE 3/4"x1'-0"x1'-6". WELD TO END RAIL POST AS SHOWN IN DETAIL REQUIRED AT BEAM GUARD ATTACHMENTS ONLY.
- ⑧ 1" DIA. HOLES IN PLATE NO.7 FOR 7/8" DIA. A325 BOLTS W/HEX NUTS AND WASHERS.
- ⑨ SQUARE SLEEVE FABRICATED FROM 1/4" PLATE. PROVIDE "SLIDING FIT" WITH A MINIMUM OUT TO OUT DIMENSION OF 3 13/32".
- ⑩ TS 3x3x.25x1'-10" LONG. PROVIDE 1/2" DIA. SURFACE WELDS ON ALL SIDES AS SHOWN. GRIND WELDS TO FIT FREE INTO I.D. OF NO.5 PROVIDE 3/8" DIA. x1/2" WELDING STUDS ON TOP AND BOTTOM SURFACES AT CENTERLINE.

GENERAL NOTES

BID ITEM SHALL BE "TUBULAR RAILING TYPE 'F'. WHICH INCLUDES ALL ITEMS SHOWN.
 RAILING SHALL BE FABRICATED IN 2 OR 3 PANEL LENGTHS.
 POSTS BASE PLATES, NO.2, SHALL BE FLAT WITH ALL SURFACES SMOOTH AND FREE FROM WARP AND ALL EDGES SMOOTH, STRAIGHT AND VERTICAL. ALL PLATE CUTS SHALL BE MACHINE OR MACHINE FLAME CUT.
 ALL MEMBERS INCLUDING UPPER 4" OF NO.3 SHALL BE GALVANIZED AFTER FABRICATION.
 FILL BOLT SLOT OPENINGS IN POSTS SHIMS AND PLATE NO.2 WITH NON-STAINING GRAY NON-BITUMINOUS JOINT SEALER.
 ALL MATERIALS USED IN FABRICATION SHALL BE MADE FROM MATERIALS CONFORMING TO A.S.T.M. DESIGNATION A36 UNLESS NOTED OTHERWISE.
 STEEL POST SHIMS MAY BE USED UNDER POSTS WHERE REQ'D. FOR ALIGNMENT.
 PRIOR TO GALVANIZING, ALL STEEL RAILING SHALL BE GIVEN A NO.6 COMMERCIAL BLAST CLEANING BY S.S.P.C. SPECIFICATIONS. BLAST CLEANING IS NOT REQUIRED FOR COLD FORMED TUBING (5). EXCEPT TO REMOVE WELDING SLAG AND IMPERVIOUS SUBSTANCES. WELD WITH E70 ELECTRODES.

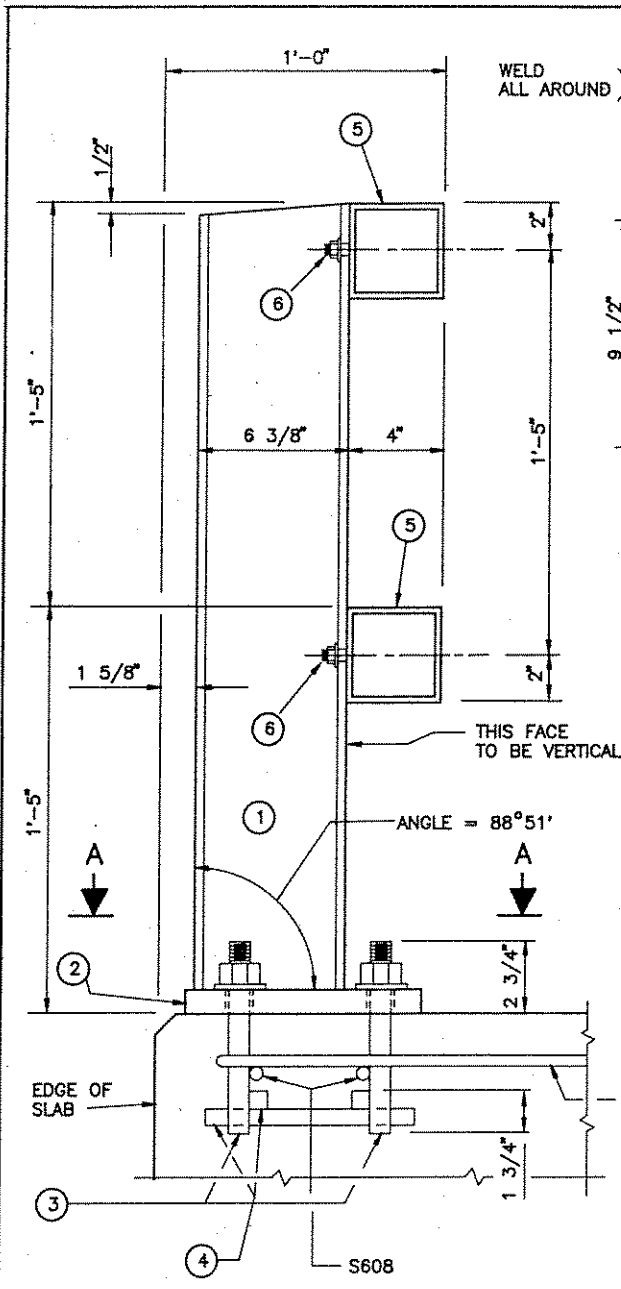

SECTION THRU RAILING

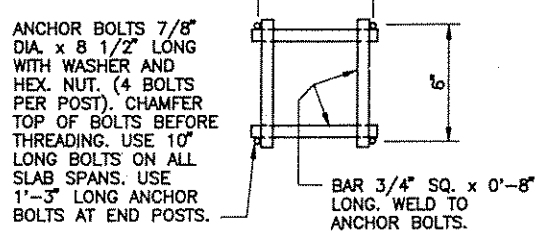

ANCHOR BOLT DETAIL

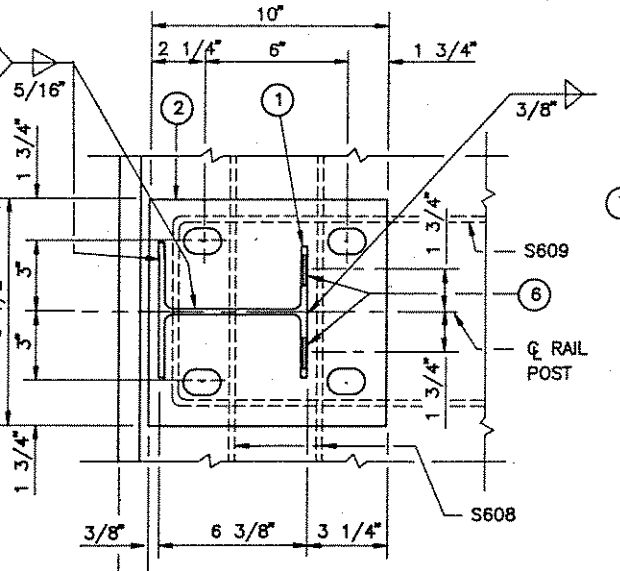

SECTION A

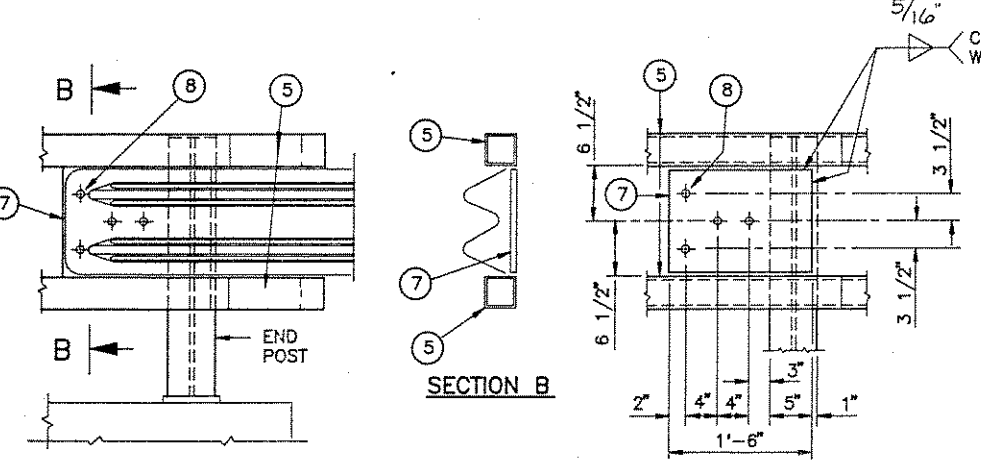

**DETAIL AT END POST
(PLATE BEAM GUARD RAIL ATTACHMENT)**

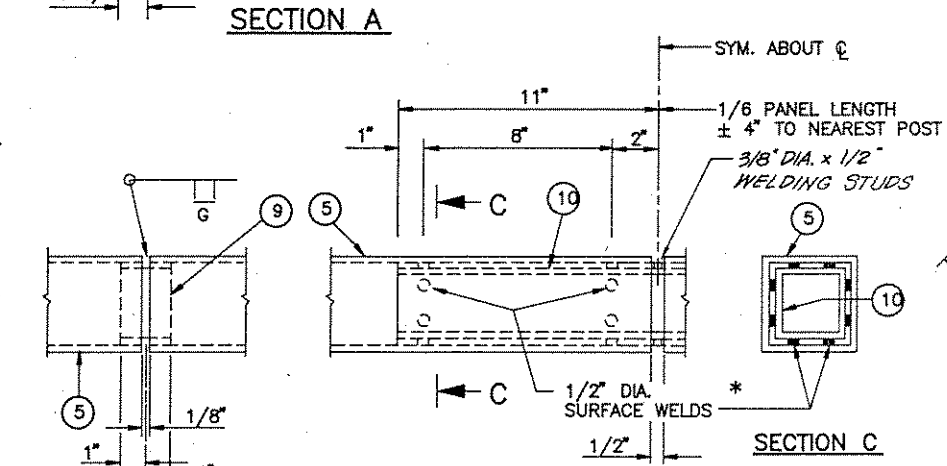

FIELD ERECTION JOINT DETAIL

* MIN. 5/8" FLAT SURFACE DIA. PUNCHINGS OR STUDS MAY BE USED AS AN ALTERNATE.

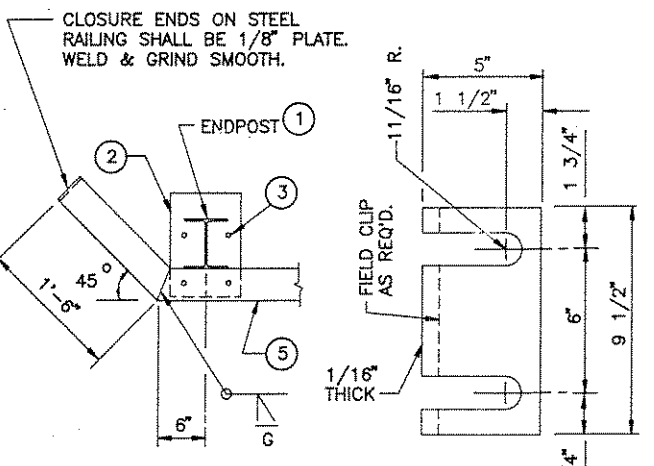

END DETAIL FOR WINGS

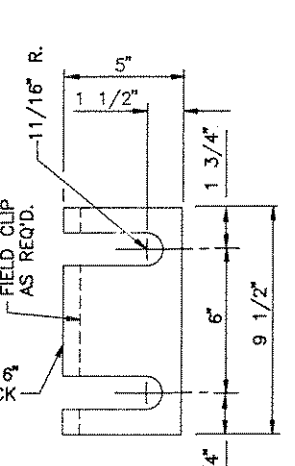

**POST SHIM DETAIL
(4 PER POST)**



**SHOP RAIL SPLICE DETAIL
(LOCATION MUST BE SHOWN ON SHOP DRAWINGS)**

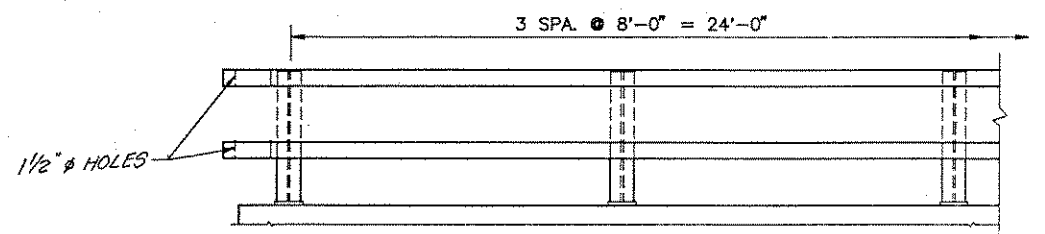

PARTIAL ELEVATION OF RAILING

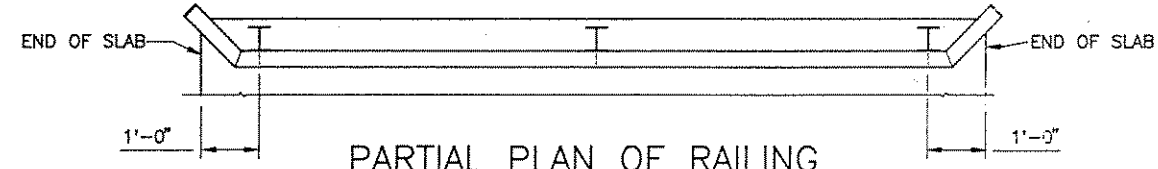

PARTIAL PLAN OF RAILING

No.	Date.	Revision	By
STATE OF WISCONSIN DEPARTMENT OF TRANSPORTATION DIVISION OF HIGHWAYS			
STRUCTURE B-35-107			
Const. Spec.	WIS. '89	Drawn By	T.L.
			Plans Checked
TUBULAR RAILING TYPE "F"			SHEET 6 OF 6
			X82701