

BILL OF BARS - ABUTMENTS

MARK	NO.	LENGTH	BEND	CUT	LOCATION
A401	96	2'-0"			FOOTING - BODY & WINGS - TOE - BTM.
A402	88	3'-6"			" - " - HEEL - TOP
A403	8	10'-0"			" - WINGS 1 & 3 - TIE BARS
A404	8	8'-0"			" - " - 2:4 - " - "
A405	16	16'-0"			" - BODY - TIE BARS
A406	78	2'-6"			" - DOVELS - FF - WINGS & BODY
A607	28	6'-1"	X		" - DOVELS - B.F. - WINGS
A608	56	9'-1"	X		" - " - " - " - BODY
A409	38	8'-0"			BODY - VERT. - F.F.
A510	56	5'-10"	X		" - STIRRUP @ SEAT
A511	54	2'-0"			" - DOVELS - TOP
A412	48	15'-2"			" - HORIZ. - FF & B.F.
A513	18	10'-7"			" - VERT. - CORNERS
A414	24	5'-10"	X		" - HORIZ. - CORNERS
A315	12	5'-2"	X		" - " - " - CORNER - STIRRUPS - TOP
A416	6	19'-3"	X		WINGS 1 & 3 - VERT. - F.F.
A517	8	15'-4"	X		" 1:3 - " - B.F.
A418	20	7'-8"			" 1:3 - HORIZ. - FF & B.F.
A419	4	6'-6"			" 1:3 - " - " - "
A420	4	7'-10"			" 1:3 - " - " - " - TOP
A421	5	18'-4"	X		WINGS 2 & 4 - VERT. - F.F.
A522	6	14'-3"	X		" 2:4 - " - B.F.
A423	20	5'-8"			" 2:4 - HORIZ. - FF & B.F.
A424	4	3'-2"			" 2:4 - " - " - "
A425	4	6'-3"			" 2:4 - TOP - FF & B.F.

THE FIRST DIGIT OF THE BAR MARK SIGNIFIES THE BAR SIZE. DIMENSIONS IN BENDING DETAILS ARE OUT TO OUT OF BAR.

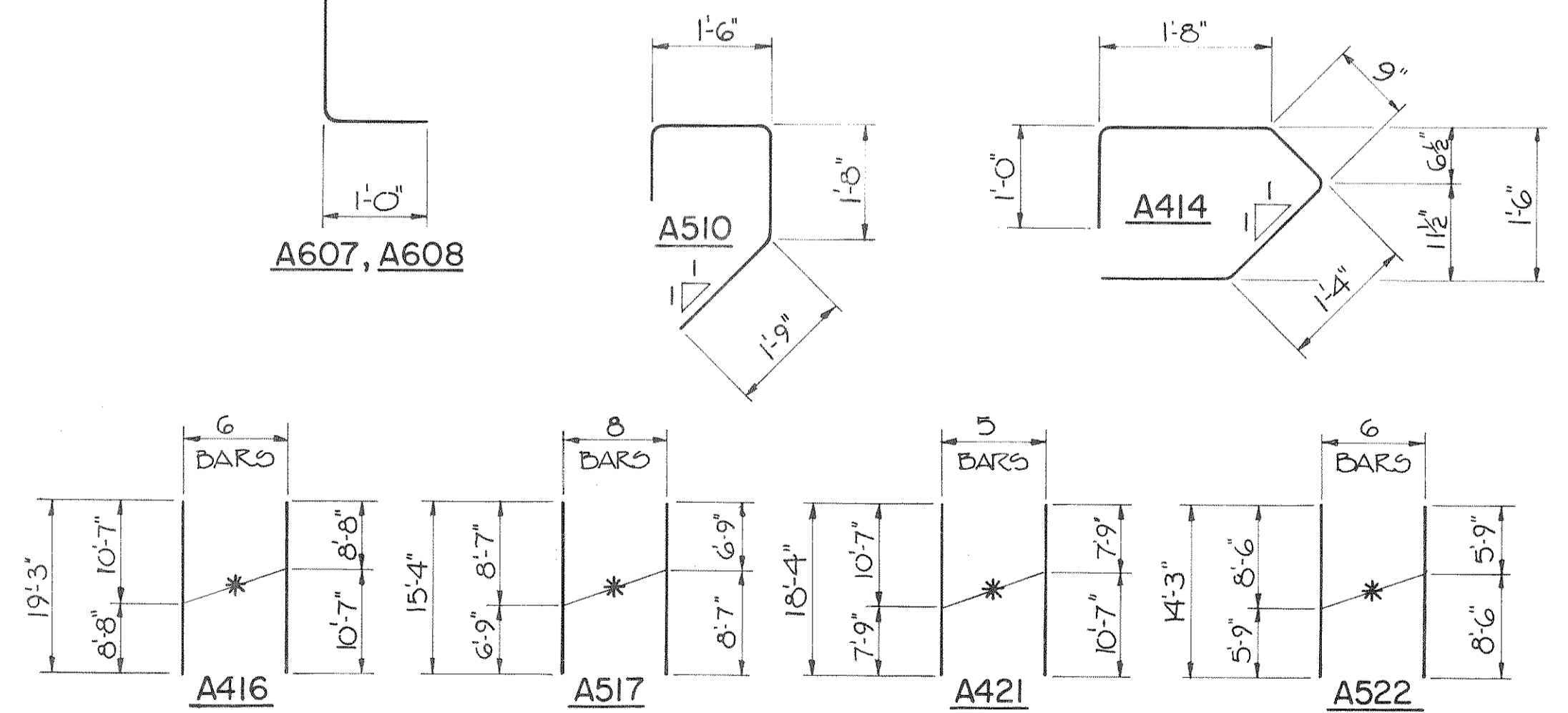
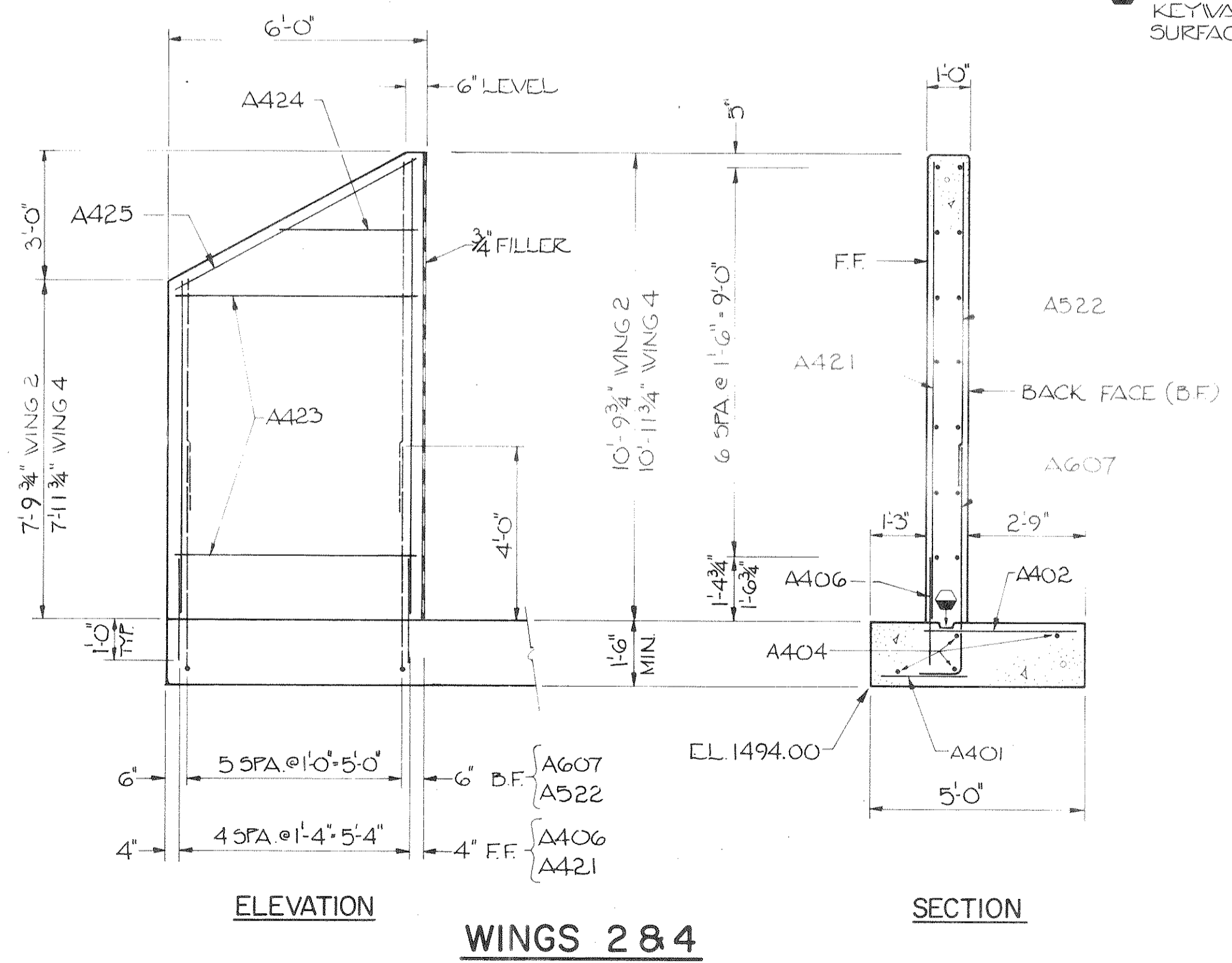

* MARK & CUT ALL BARS ALONG THIS LINE MAKE ALL CUTS NORMAL TO BAR AXIS.

CUTTING DIAGRAMS

No.	Date	Revision	By
STATE OF WISCONSIN DEPARTMENT OF TRANSPORTATION DIVISION OF HIGHWAYS			
STRUCTURE B-35-90			
Const. Spec.	WIS. '81	Drawn By	ORL
Plans Checked	L.M.D.		
ABUTMENT DETAILS			SHEET 4 OF 6
			X 77133